



4331 EUCALYPTUS AVE. CHINO, CA. 91710
Phone 909-597-7800 FAX 909-597-7185

#FTS1500-10 AND #FTS1500-11
1988-98 CHEVROLET 2 WHEEL DRIVE C1500/C2500 6 LUG
UPPER AND LOWER CONTROL ARM KIT

PARTS LIST:

1 EA. (UCA) FT1500-10UP / FT1500-11UP	1 EA. (UCA) FT1500-10-UD / FT1500-11UD
4 EA. UCA INNER BUSHINGS FT1002	4 EA. UCA OUTER BUSHINGS FT1001
4 EA. UCA SLEEVES FT1500-6-101	2 EA. GREASE FITTINGS FT84H
1 EA. (LCA) FT1500-10LP	1 EA. (LCA) FT1500-10LD
4 EA. LCA FRONT BUSHINGS FT1000	4 EA. LCA REAR BUSHINGS FT1006
2 EA. LCA FRONT SLEEVES FT1500-10-102	2 EA. LCA REAR SLEEVES FT1500-10-103
2 EA. LOWER BUMPSTOPS FTS86	2 EA. SILICON LUBE FTLUBE
4 EA. 5/16" X 1" BOLTS	4 EA. 5/16" LOCK WASHERS
8 EA. 5/16" SAE WASHERS	2 EA. TIE ROD SLEEVES FT1500-10-3
2 EA. RIGHT HAND JAM NUT FT1500-10-1	2 EA. LEFT HAND JAM NUT FT1500-10-2
2 EA. FRONT SMALL GUSSET PLATES	2 EA. REAR LARGE GUSSET PLATES

TOOL LIST: (NOT INCLUDED)

FLOOR JACK	JACK STANDS
BALL JOINT PRESS	
ASSORTED METRIC AND S.A.E SOCKETS, & ALLEN WRENCHES	

CHECK ALL PARTS INCLUDED IN THIS KIT TO THE PARTS LIST ABOVE BEFORE BEGINNING INSTALLATION OF THE KIT. IF ANY PIECES ARE MISSING, CONTACT FABTECH AT 909-597-7800.

READ ALL INSTRUCTIONS THOROUGHLY FROM START TO FINISH BEFORE BEGINNING INSTALLATION!

IF THESE INSTRUCTIONS ARE NOT PROPERLY FOLLOWED, SEVERE FRAME OR SUSPENSION DAMAGE MAY RESULT TO THE VEHICLE.

VEHICLES THAT WILL RECEIVE OVERSIZED TIRES SHOULD CHECK BALL JOINTS, TIE RODS ENDS AND IDLER ARM EVERY 2500-5000 MILES FOR WEAR AND REPLACE AS NEEDED

THE INSTALLATION OF THE GUSSET KIT INCLUDED WITH THIS KIT REQUIRES WELDING WHICH SHOULD ONLY BE PERFORMED BY AN EXPERIENCED WELDER.

CHECK ALL PARTS INCLUDED IN THIS KIT TO THE PARTS LIST ABOVE BEFORE BEGINNING INSTALLATION OF THE KIT. IF ANY PIECES ARE MISSING, CONTACT FABTECH AT 909-597-7800

WARNING: FABTECH RECOMMENDS THAT YOU EXERCISE EXTREME CAUTION WHEN WORKING WITH COIL SPRINGS TO AVOID ANY POSSIBILITY OF INJURY.

INSTRUCTIONS:

1. Jack up the front end of the truck and support the frame rails with jack stands. **NEVER WORK UNDER AN UNSUPPORTED VEHICLE!** Remove both front tires.
2. Starting on the driver's side of the truck, support the lower control arm (LCA) with a jack, enough to remove the tension from the shock. Remove the front shock, sway bar end link and brake caliper. Secure the brake caliper to the frame of the truck, **DO NOT LET IT HANG FROM THE LINE!** Remove the cotter pin and castle nut holding the upper and lower ball joints to the spindle, if your truck has ABS brakes, remove the sensor from the spindle and secure it to the frame. Separate the ball joints from the spindle and set the spindle aside. Lower the jack supporting the LCA to release the coil spring, **USE EXTREME CAUTION, THE COIL SPRINGS CAN BE UNDER HIGH LOAD!** Remove the two bolts attaching the brake line to the upper control arm, on late model trucks you will need to also separate the ABS wire from the UCA. Remove the two nuts on the UCA alignment cams, attaching the UCA to the frame. Remove the two alignment bolts and set the stock UCA aside. If the factory alignment tabs have not been knocked out, you may want to remove them at this time. To remove the alignment pins you can use a hammer and chisel or you can purchase a special tool from you local GM dealer.
3. Remove the two bolts at the pivot points of the LCA. Set the bolts aside and remove the LCA. Using a ball joint press remove the lower ball joint from the LCA and set the ball joint aside.
4. Remove the rivets holding the upper ball joint to the stock UCA, you can do this by grinding off the heads of the rivets and punching them through the UCA. Take the driver's side upper control arm, it will have the grease fittings on top and the brake line mount and sticker on the front tube, attach the ball joint to the lift UCA using your ball joint flip kit hardware supplied with the lift coil springs. The top of the upper ball joint should rest against the bottom side of the UCA. Insert the bolts from the bottom, with the nuts and washers on top of the UCA. Install the supplied grease fittings onto the UCA bushing ends. Be sure to thoroughly lubricate all bushings and sleeves before you press them into the UCA with the supplied lube. Press the bushings into the UCA, starting with the FTS1001 part number on the insides of the bushing tubes, facing each other and FTS1002 on the outsides, see figure 1. Next install one sleeve into the bushings (four bushings and two sleeves per UCA). Also, install a low profile bumpstop (2" round and 5/8" thick urethane), onto the UCA.
5. Using a solvent like acetone, remove the black wax off the frame on the UCA mounts. Tack weld the UCA gussets into place as shown on the supplied drawing. Slide the UCA back into the frame mount and be sure there is adequate clearance between the UCA and the new gussets. Completely weld both sides of the gusset onto the frame and UCA mount. When all the welded areas have cooled, paint all exposed areas.
6. Slide the UCA into the UCA mount and reinstall the factory bolts the same way they were removed. We recommend you center the alignment cams in the adjustment pockets.
7. Take the drivers side lower control arm, it will have the sway bar and bumpstop mount on the front side, using the ball joint press install your lower ball joint into the new LCA through the bottom pointing up. The ball joint direction will be the same as it was in the old LCA. Install the grease fittings on the bottom threaded holes of LCA bushing mounts. Take the supplied lower bumpstop, 2" x 2" x 2" square urethane, apply thread locking compound to the bumpstop and thread it into the LCA. Prepare the LCA bushings for installation. Start by setting aside the front LCA bushing (FTS1000) and sleeve (3.6" long). Next, set aside the rear LCA bushing (shorter than FTS1000 with no part number) and sleeve (3" long). Lubricating all

bushings and sleeves thoroughly, insert the front bushings into the barrel, the front barrel has 2 gussets welded on top, followed by the matching sleeve. Install the rear LCA bushings and sleeves last.

8. Loosen the clinch bolts on the tie rod adjuster and completely unthread the outer tie rod and adjuster assembly from the inner tie rod. Unthread the adjuster from the outer tie rod and discard the adjuster sleeve. Thread the new adjuster sleeve onto the inner and outer tie completely until the threads bottom out.
9. Slide the LCA into the frame pockets and reinstall the factory bolts the same direction they were removed. Torque the nuts to factory specifications. Support the LCA with a jack and install your lift coil springs, following the instructions included with the coil kit. With the coil spring set in position, place the spindle, stock or lift spindle, back onto the upper and lower ball joints. Torque the original castle nuts to factory specifications and install new cotter pins, **DO NOT REUSE THE ORIGINAL COTTER PINS!** Reattach the tie rod to the spindle and torque the nut to factory specs. Install the brake caliper back onto the spindle using the factory bolts. Attach the brake line support tab onto the UCA with the factory bolts, for stock spindles use the top tab and for lift spindles use the lower tab. Secure the ABS sensor wire, if equipped, to the brake line using cable ties. You may have to bend the upper brake line tab to straighten the direction of the brake line and slide the line down through the support tab. If you are using a single shock in the stock position install it at this point, using the supplied 5/16" hardware. Also, attach the sway bar, using the factory hardware, to the new mount on the LCA be sure the bolt comes through the LCA first with the nut on top.
10. Lower the jack supporting the LCA. Repeat steps 2 through 7 on the passenger's side of the truck.
11. Reinstall the front wheels and torque the lugs to factory specifications. Check all newly installed fasteners making sure they are fully torqued. Lower the truck onto the ground. While turning the wheels fully in each direction check all clearances between tires, wheels and be sure the brake line has plenty of movement. Set the toe-in to approximate factory specs. We recommend driving the truck for approximately fifty miles and then have the truck aligned to factory specifications.

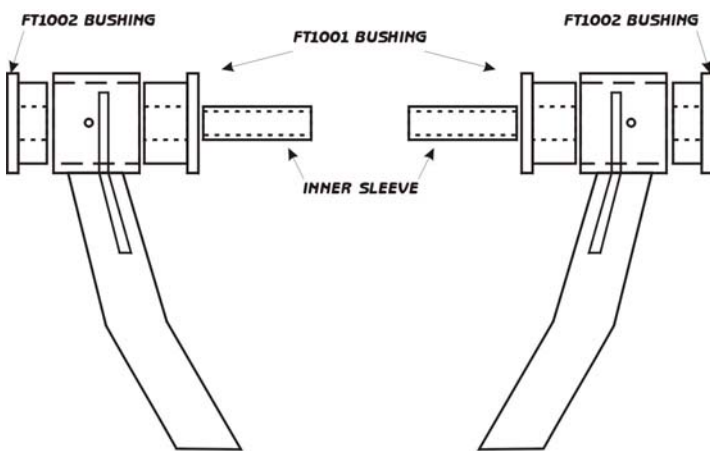
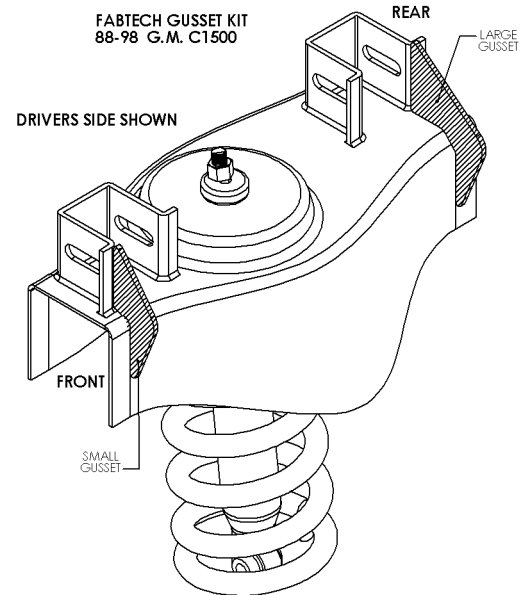

FIGURE 1



RETORQUE ALL NUTS, BOLTS AND LUGS AFTER 50 MILES AND PERIODICALLY THEREAFTER.

For technical assistance call: 909-597-7800

Product Warranty and Warnings-

Fabtech provides a Limited Lifetime Warranty to the original retail purchaser who owns the vehicle, on which the product was originally installed, for defects in workmanship and materials.

The Limited Lifetime Warranty excludes the following Fabtech items; bushings, bump stops, ball joints, tie rod ends, limiting straps, cross shafts, heim joints. These parts are subject to wear and are not considered defective when worn. They are warranted for 60 days from the date of purchase for defects in workmanship.

Coil over take apart shocks are considered a serviceable shock with a one year warranty on leakage only. Service seal kits are available separately for future maintenance. All other shocks are covered under our Limited Lifetime Warranty.

Fabtech does not warrant any product for finish, alterations, modifications and/or installation contrary to Fabtech's instructions. Alterations to the finish of the parts including but not limited to painting, powdercoating, plating and/or welding will void all warranties. Some finish damage may occur to parts during shipping which is considered normal and is not covered under warranty.

Fabtech products are not designed nor intended to be installed on vehicles used in race applications or for racing purposes or for similar activities. (A "RACE" is defined as any contest between two or more vehicles, or any contest of one or more vehicle against the clock, whether or not such contest is for a prize). This warranty does not include coverage for police or taxi vehicles, race vehicles, or vehicles used for government or commercial purposes. Also excluded from this warranty are sales outside of the United States of America.

Installation of most suspension products will raise the center of gravity of the vehicle and will cause the vehicle to handle differently than stock. It may increase the vehicle's susceptibility to a rollover, on road and off road, at all speeds. Extreme care should be taken to operate the vehicle safely at all times to prevent rollover or loss of control resulting in serious injury or death. Fabtech front end Desert Guards may impair the deployment or operation of vehicles equipped with supplemental restraining systems/air bag systems and should not be installed if the vehicle is equipped as so.

Fabtech makes every effort to ensure suspension product compatibility with all vehicles listed in the catalog, but due to unknown auto manufacturers production changes and/or inconsistencies by the auto manufacturer, Fabtech cannot be responsible for 100% compatibility, including the fitment of tire and wheel sizes listed. The Tire and Wheel sizes listed in Fabtech's catalog are only a guideline for street driving with noted fender trimming. Fabtech is not responsible for damages to the vehicle's body or tires.

Fabtech's obligation under this warranty is limited to the repair or replacement, at Fabtech option, of the defective product only. All costs of removal, installation or re-installation, freight charges, incidental or consequential damages are expressly excluded from this warranty. Fabtech is not responsible for damages and/or warranty of other vehicle parts related or non related to the installed Fabtech product. This warranty is expressly in lieu of all other warranties expressed or implied. This warranty shall not apply to any product that has been subject to accident, negligence, alteration, abuse or misuse as determined by Fabtech.

Fabtech suspension components must be installed as a complete system including shocks as shown in our current catalog. All warranties will become void if Fabtech parts are combined and/or substituted with other aftermarket suspension products. Combination and/or substitution of other aftermarket suspension parts may cause premature wear and/or product failure resulting in an accident causing injury or death. Fabtech does not warrant products not manufactured by Fabtech.

Installation of Fabtech product may void the vehicles factory warranty; it is the consumer's responsibility to check with their local vehicle's dealer for warranty disposition before the installation of the product.

It is the responsibility of the distributor and/or the retailer to review all warranties and warnings of Fabtech products with the consumer prior to purchase.

Fabtech reserves the right to supercede, discontinue, change the design, finish, part number and, or application of parts when deemed necessary without written notice. Fabtech is not responsible for misprints or typographical errors within the catalog or price sheet.