



www.fabtechmotorsports.com

4331 EUCALYPTUS AVE. ~~ CHINO, CA 91710
PHONE 909-597-7800 FAX 909-597-7185
2000-2003 TOYOTA TUNDRA 2WD & 4WD
FTS2600K 0"- 2.5" COIL OVER SYSTEM

Parts List:

Qua	Part #	Description
2	FT70040	Coil Over Assembly
1	FT30101	Spanner Wrench
1	FT2600Ki	Instruction Sheet
1	FTAS16	Driver Warning Sticker
1	FTAS12	Sticker

Tool List:

- Floor Jack & Jack Stands
- Assorted Metric Wrenches & Sockets
- Allen Wrench Set
- Torque Wrench

READ ALL INSTRUCTIONS THOROUGHLY FROM START TO FINISH BEFORE BEGINNING INSTALLATION!

CHECK ALL PARTS INCLUDED IN THIS KIT TO THE PARTS LIST ABOVE BEFORE BEGINNING INSTALLATION OF THE KIT. IF ANY PIECES ARE MISSING, CONTACT FABTECH AT 909-597-7800.

WARNING: FABTECH RECOMMENDS THAT YOU EXERCISE EXTREME CAUTION WHEN WORKING WITH COIL SPRINGS TO AVOID POSSIBILITY OF SERIOUS INJURY.

THESE COIL OVER ASSEMBLIES ARE CHARGED WITH NITROGEN GAS. DO NOT RELEASE ANY PRESSURE DURING THE INSTALLATION OF THIS KIT! BY RELEASING PRESSURE FROM THE SHOCK YOU WILL IMMEDIATELY VOID THE WARRANTY! ANY DISASSEMBLY ON THESE SHOCKS MUST BE PERFORMED BY AN EXPERIENCED SHOCK TECHNICIAN.

VEHICLES THAT WILL RECEIVE OVERSIZED TIRES SHOULD CHECK BALL JOINTS, TIE RODS ENDS AND IDLER ARM EVERY 2500-5000 MILES FOR WEAR AND REPLACE AS NEEDED.

FTS2600K COIL-OVER SHOCK CARRIES A 1-YEAR WARRENTY. CONTACT FABTECH FOR MORE INFORMATION.

INSTRUCTIONS:

1. With the truck sitting on a flat and level surface, measure the distance from the center of the front spindle to the top of the fender opening. Write this measurement down, you will need to refer back to it later.
2. Jack up the front end of the truck and support the frame rails with jack stands. **NEVER WORK UNDER AN UNSUPPORTED VEHICLE!** Remove the front tires and remove the sway bar endlinks.
3. Remove the three nuts securing the upper spring seat to the frame mount. Leave the upper spring seat/strut assembly nut attached. Remove the nut and bolt securing the bottom of the spring seat/strut assembly to the lower control arm and remove the assembly from the truck.
4. Take the new assembled coil over shock and position it onto the truck. Using the supplied 3/8" bolts and washers secure the new aluminum spring seat to the upper spring mount. **SEE DRAWING ON LAST PAGE FOR CORRECT BOLT HOLES.** Using the original lower nut and bolt and the supplied mis-alignments, secure the lower coil over mount to the lower control arm. When installing the supplied mis-alignments the larger one goes to the rear and the smaller goes to the front. **SEE DRAWING ON LAST PAGE.**
5. Torque the three top bolts on the upper spring seat to 28 ft/lbs. And torque the lower coil-over mount to 65 ft/lbs. Tighten the coil spring collar on the coil-over until you start to compress the coil spring. Make sure the coil spring is seated on the top and bottom and properly resting on the aluminum collar. Continue to tighten the upper collar by hand until you can go no farther. Using the supplied spanner wrench, tighten the spring collar until there is 2 3/4" of thread exposed above the upper spring collar. Tighten the locking Allen bolt on the upper spring collar.
6. Repeat steps three through five on the opposite side of the truck.
7. Reinstall the front tires and torque the front lug nuts to factory specifications, factory torque specifications can be found in your owners manual. Raise the front of the truck off of the jack stands and set it back onto the ground.
8. Front ride height can be set from 0" to 2.5" over the original ride height. **DO NOT EXCEED 2.5" OVER ORIGINAL RIDE HEIGHT.** Measure the distance from the center of the front spindle to the top of the fender opening. Compare this with your original measurement and adjust the ride height as desired. To make adjustments to the ride height of your truck, jack up the front end of the truck and support the frame rails with jack stands. **NEVER WORK UNDER AN UNSUPPORTED VEHICLE!** Loosen the locking Allen bolt on the upper spring collar and either tighten or loosen the collar using the supplied spanner wrench. Make adjustments two turns per measurement, be sure to tighten the locking Allen bolt on the upper spring collar to 20 ft/lbs. prior to setting the truck back on the ground.
9. After you have set the proper ride height, reinstall the front sway bar links and check the toe in of the front tires. Adjust the toe in if necessary and test drive the truck. Check the torque on all newly installed hardware and make any ride height adjustments if necessary. Measure the ride height after 50 miles, adjust if necessary and have the truck aligned to factory specifications.

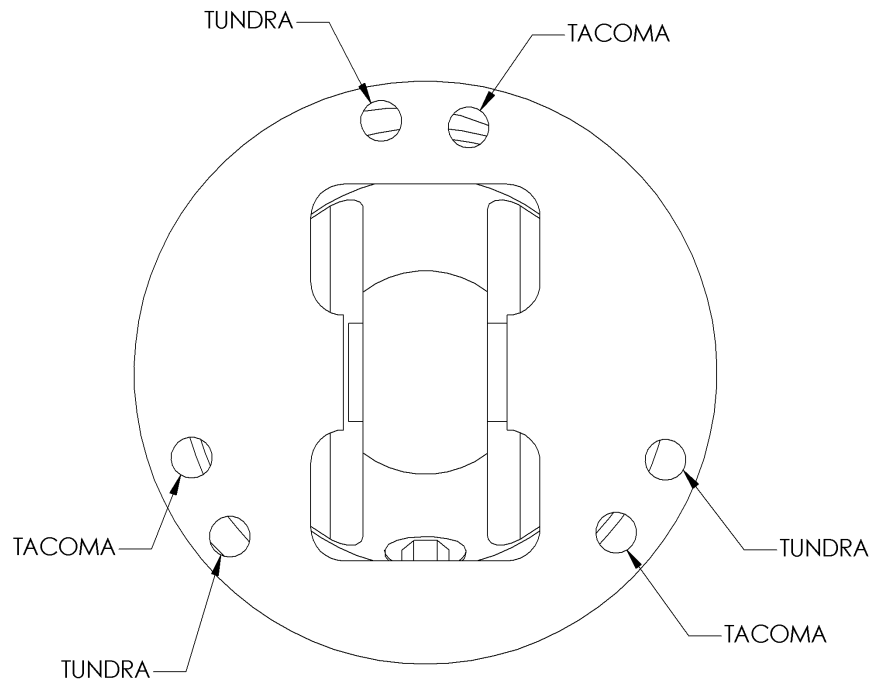

VIEW OF TOP ALUMINUM SPRING SEAT

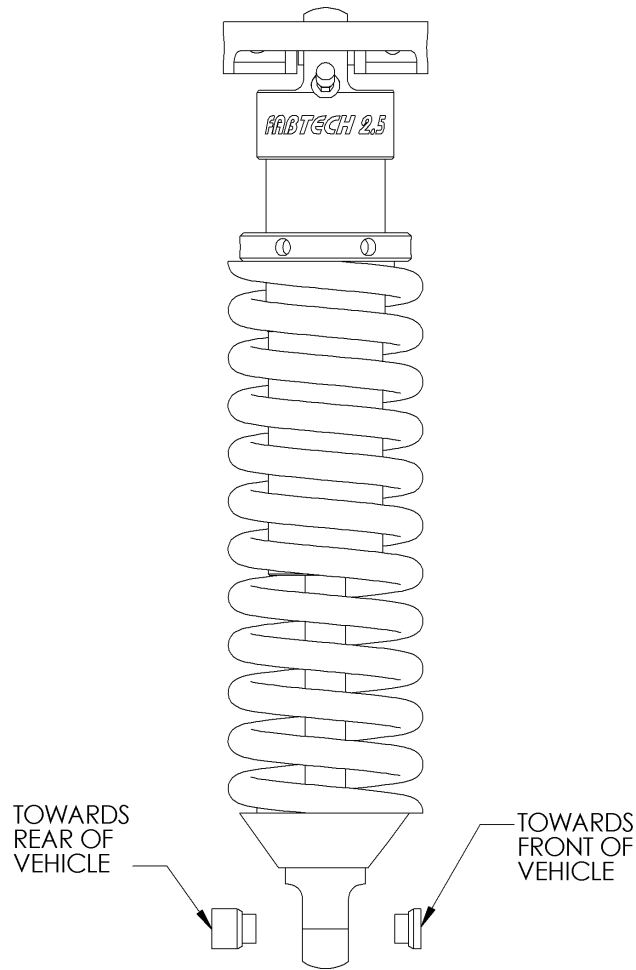

VIEW OF MIS-ALIGNMENT ASSEMBLY

RETORQUE ALL NUTS, BOLTS AND LUGS AFTER 50 MILES AND PERIODICALLY THEREAFTER.

For technical assistance call: 909-597-7800

Product Warranty and Warnings

Fabtech provides a Limited Lifetime Warranty to the original retail purchaser who owns the vehicle, on which the product was originally installed, for defects in workmanship and materials.

The Limited Lifetime Warranty excludes the following Fabtech items; bushings, bump stops, ball joints, tie rod ends, limiting straps, cross shafts, heim joints. These parts are subject to wear and are not considered defective when worn. They are warranted for 60 days from the date of purchase for defects in workmanship.

Coil over take apart shocks are considered a serviceable shock with a one year warranty on leakage only. Service seal kits are available separately for future maintenance. All other shocks are covered under our Limited Lifetime Warranty.

Fabtech does not warrant any product for finish, alterations, modifications and/or installation contrary to Fabtech's instructions. Alterations to the finish of the parts including but not limited to painting, powdercoating, plating and/or welding will void all warranties. Some finish damage may occur to parts during shipping which is considered normal and is not covered under warranty.

Fabtech products are not designed nor intended to be installed on vehicles used in race applications or for racing purposes or for similar activities. (A "RACE" is defined as any contest between two or more vehicles, or any contest of one or more vehicle against the clock, whether or not such contest is for a prize). This warranty does not include coverage for police or taxi vehicles, race vehicles, or vehicles used for government or commercial purposes. Also excluded from this warranty are sales outside of the United States of America.

Installation of most suspension products will raise the center of gravity of the vehicle and will cause the vehicle to handle differently than stock. It may increase the vehicle's susceptibility to a rollover, on road and off road, at all speeds. Extreme care should be taken to operate the vehicle safely at all times to prevent rollover or loss of control resulting in serious injury or death. Fabtech front end Desert Guards may impair the deployment or operation of vehicles equipped with supplemental restraining systems/air bag systems and should not be installed if the vehicle is equipped as so.

Fabtech makes every effort to ensure suspension product compatibility with all vehicles listed in the catalog, but due to unknown auto manufacturers production changes and/or inconsistencies by the auto manufacturer, Fabtech cannot be responsible for 100% compatibility, including the fitment of tire and wheel sizes listed. The Tire and Wheel sizes listed in Fabtech's catalog are only a guideline for street driving with noted fender trimming. Fabtech is not responsible for damages to the vehicle's body or tires.

Fabtech's obligation under this warranty is limited to the repair or replacement, at Fabtech option, of the defective product only. All costs of removal, installation or re-installation, freight charges, incidental or consequential damages are expressly excluded from this warranty. Fabtech is not responsible for damages and/or warranty of other vehicle parts related or non related to the installed Fabtech product. This warranty is expressly in lieu of all other warranties expressed or implied. This warranty shall not apply to any product that has been subject to accident, negligence, alteration, abuse or misuse as determined by Fabtech.

Fabtech suspension components must be installed as a complete system including shocks as shown in our current catalog. All warranties will become void if Fabtech parts are combined and/or substituted with other aftermarket suspension products. Combination and/or substitution of other aftermarket suspension parts may cause premature wear and/or product failure resulting in an accident causing injury or death. Fabtech does not warrant products not manufactured by Fabtech.

Installation of Fabtech product may void the vehicles factory warranty; it is the consumer's responsibility to check with their local vehicle's dealer for warranty disposition before the installation of the product.

It is the responsibility of the distributor and/or the retailer to review all warranties and warnings of Fabtech products with the consumer prior to purchase.

Fabtech reserves the right to supercede, discontinue, change the design, finish, part number and, or application of parts when deemed necessary without written notice. Fabtech is not responsible for misprints or typographical errors within the catalog or price sheet.