



www.fabtechmotorsports.com

**4331 EUCALYPTUS AVE. ~~ CHINO, CA 91710  
 909-597-7800 FAX 909-597-7185  
 1998-08 FORD RANGER TWO WHEEL DRIVE  
 FTS98100-6BJ UPPER CONTROL ARM KIT**

**PARTS LIST:**

<b>FTS98100-6BJ</b>		<b>98 Ranger UCA With Ball Joints</b>
<b>Qua</b>	<b>Part #</b>	<b>Description</b>
1	FT30371	Hdwr Sub-Assembly Kit
1	FT98100-6BD	Bump Stop Mount Driver
1	FT98100-6BP	Bump Stop Mount Passenger
1	FT98100-6DBJ	UCA with Hardware Driver
1	FT98100-6PBJ	UCA with Hardware Passenger

<b>FT30371</b>		<b>Hdwr Sub-Assembly Kit</b>
<b>Qua</b>	<b>Part #</b>	<b>Description</b>
4	12002007000	Cotter Pin
14	37000005052	3/8" SAE Flat Washer
8	37160003052	3/8"-16 Nylok Nut
6	37161001052	3/8"-16 X 1" Hex Bolt
8	FT1003	Bushing
4	FT7100-6-100	Sleeve
4	FT84	Grease Fitting
2	FT98100-6BJi	Instructions
1	FTAS12	Sticker
1	FTAS16	Driver Warning Decal
2	FTLUBE	Lube
1	FTREGCARD	Registration Card
2	FTS88	Bumpstop
2	FTSBP5	Bar Pin

**CHECK ALL PARTS INCLUDED IN THIS KIT TO THE PARTS LIST ABOVE BEFORE BEGINNING INSTALLATION OF THE KIT. IF ANY PIECES ARE MISSING, CONTACT FABTECH AT 909-597-7800**

**TOOL LIST: (NOT INCLUDED)**

- FLOOR JACK AND JACK STANDS**
- ASSORTED METRIC AND S.A.E SOCKETS, & ALLEN WRENCHES**
- CLAMPS**
- DRILL WITH 3/8" BIT**

**THIS KIT MUST BE INSTALLED WITH FTS98100-2 OR FTS98100-3 COIL SPRINGS AND FTS9119 FRONT SHOCKS, NOT SUPPLIED WITH THIS KIT.**

**VEHICLES THAT WILL RECEIVE OVERSIZED TIRES SHOULD CHECK BALL JOINTS, TIE RODS ENDS AND IDLER ARM EVERY 2500-5000 MILES FOR WEAR AND REPLACE AS NEEDED.**

**TRUCKS THAT DO NOT HAVE ADJUSTABLE ALIGNMENT CAMS ON THE UPPER CONTROL ARM PIVOT BOLTS MUST USE A FTS290 ALIGNMENT CAM KIT FOR PROPER ALIGNMENT.**

**LARGER TIRES CANNOT BE INSTALLED ON OEM WHEELS. TO INSTALL LARGER TIRES YOU MUST USE AFTERMARKET WHEELS WITH A MAXIMUM 4" BACKSPACING.**

**READ ALL INSTRUCTIONS THOROUGHLY FROM START TO FINISH BEFORE BEGINNING INSTALLATION! IF THESE INSTRUCTIONS ARE NOT PROPERLY FOLLOWED, SEVERE FRAME, SUSPENSION AND TIRE DAMAGE MAY RESULT TO THE VEHICLE. WARNING: FABTECH**

**RECOMMENDS THAT YOU EXERCISE EXTREME CAUTION WHEN WORKING WITH COIL SPRINGS TO AVOID ANY POSSIBILITY OF INJURY.**

**INSTRUCTIONS:**

1. Disconnect the negative terminal on the battery. Jack up the front end of the truck and support the frame rails with jack stands. **NEVER WORK UNDER AN UNSUPPORTED VEHICLE!** Remove the front tires.
2. Starting on the passenger side of the truck, support the lower control arm (LCA) with a jack. Remove the front shock and sway bar end link. Remove the front brake caliper and tie it up out of the way. **DO NOT LET THE CALIPER HANG BY THE BRAKE LINE!** Remove the nut securing the tie rod onto the spindle knuckle and separate the tie rod from the spindle. Remove the cotter pin and nut securing the lower ball joint to the spindle and separate the ball joint from the spindle. Set the spindle aside. Lower the jack supporting the lower control arm to release the coil spring. **USE EXTREME CAUTION, THE COIL SPRING IS UNDER HIGH LOAD.** Remove the coil spring, keeping the upper coil spring insulator, it will be reused later.
3. Remove the clinch bolt securing the upper ball joint to the top of the spindle. Separate the ball joint from the spindle. Remove the two nuts on the UCA alignment cams, attaching the UCA to the frame. Remove the two alignment bolts and set the stock UCA aside.
4. Take the UCA marked passenger and install the supplied grease fittings onto the UCA bushing ends. Using the supplied lube, lubricating all parts, press two bushing into each UCA end, followed by one sleeve (four bushings and two sleeves per UCA) as shown in figure 1.
5. On the outer section of frame rail, below the front upper control arm mount, locate the two ¼” slotted holes. Take the upper bumpstop mount marked passenger side and hold it against the outside of the frame. The top of the upper bumpstop mount, with the single hole, will wrap around the top of the frame. Center the two 3/8” holes in the upper bumpstop mount with the two ¼” slotted holes in the frame and clamp the upper bumpstop mount in place. Make sure the top plate on the upper bumpstop mount is resting flush on the frame rail. Using a 3/8” drill bit, drill out the ¼” slotted holes. Using the supplied 3/8” bolts, washers and lock nuts, attach the upper bumpstop mount to the frame. Insert the bolts through the mount with a flat washer under the head of the bolt and place a washer and lock nut on the inside of the frame rail. Torque to 30 ft/lbs. The inside of the frame can be accessed through the coil spring opening. Remove the clamp securing the upper bumpstop mount to the frame. Using a 3/8” drill bit, drill the hole located in the top of the upper bumpstop mount. Install a supplied 3/8” bolt, washer and lock nut. Torque to 30 ft/lbs. Install one of the supplied low profile bumpstops into the upper bumpstop mount using a 3/8” flat washer and lock nut, do not overtighten the nut.
6. Slide the UCA into the mounts on the frame. Insert the alignment cam bolts through the mounts and the UCA bushings the same direction they were removed. **IF THE TRUCK DOES NOT HAVE ADJUSTABLE ALIGNMENT CAMS, YOU MUST INSTALL A FTS291 ALIGNMENT CAM KIT TO PERFORM ANY FORM OF ALIGNMENT AFTER THE INSTALLATION OF THIS KIT.** Center the alignment cams and torque to 60 ft/lbs.

7. Take one of the new coil springs and locate the top side, the logo and part number will be at the top of the coil spring. Secure the factory upper coil insulator onto the top of the coil spring using electric tape. Slide the top of the coil spring into the frame pocket and push the bottom of the coil spring onto the lower control arm, making sure the coil spring is timed properly with the pockets in the lower control arm. Support the lower control arm with a floor jack. Using prybars, pop the bottom of the coil spring into position and raise the jack to support the lower control arm, **DO NOT LIFT THE TRUCK OFF OF THE JACK STANDS**. Set the spindle back onto the lower ball joint and hand torque the castle nut. Attach the upper ball joint to the spindle and reinstall the clinch nut to secure the upper ball joint into the spindle. Torque the lower ball joint castle nut to 70 ft/lbs. and install a new cotter pin. Torque the clinch bolt to 30 ft/lbs. Reinstall the tie rod onto the spindle and torque the castle nut to 60 ft/lbs, install a new cotter pin. Reinstall the brake caliper onto the spindle. Install a new FTS9119 front shock, using the supplied lower bar pin, onto the truck.
8. Repeat steps 2-7 on the opposite side of the truck.
9. Reinstall the sway bar using the factory end links and the front wheels. Torque the lugs to factory specifications. Lower the truck onto the ground. **WHILE TURNING THE STEERING FULLY IN EACH DIRECTION, BE SURE THAT THERE IS NO INTERFERENCE BETWEEN ANY OF THE NEWLY INSTALLED PARTS**. Set the toe-in to approximate factory specs. We recommend driving the truck for approximately fifty miles and then have the truck aligned to factory specs. Re-adjust headlights.

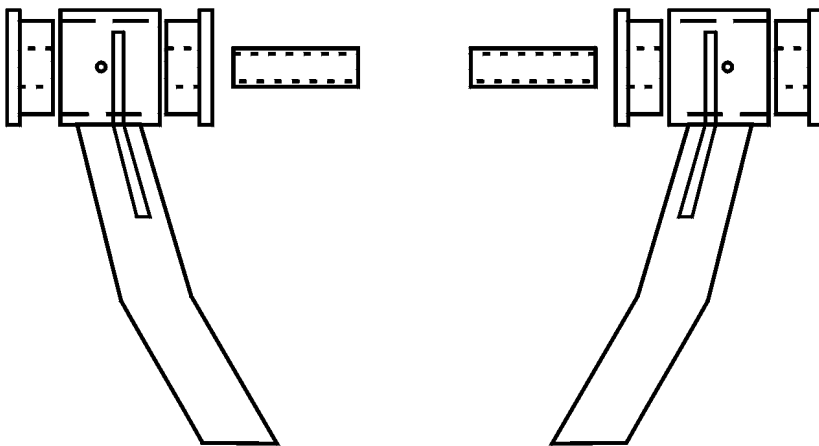

Figure 1

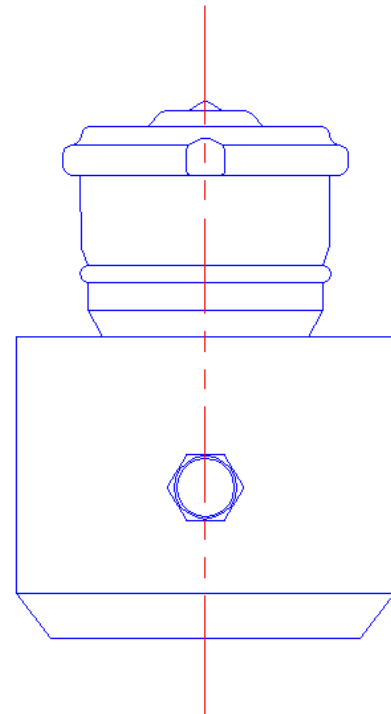

Figure 2

**RETORQUE ALL NUTS, BOLTS AND LUGS AFTER 50 MILES AND PERIODICALLY THEREAFTER.**

For technical assistance call: 909-597-7800

## Product Warranty and Warnings-

Fabtech provides a Limited Lifetime Warranty to the original retail purchaser who owns the vehicle, on which the product was originally installed, for defects in workmanship and materials.

The Limited Lifetime Warranty excludes the following Fabtech items; bushings, bump stops, ball joints, tie rod ends, limiting straps, cross shafts, heim joints. These parts are subject to wear and are not considered defective when worn. They are warranted for 60 days from the date of purchase for defects in workmanship.

Take apart shocks are considered a serviceable shock with a one year warranty on leakage only. Service seal kits are available separately for future maintenance. All other shocks are covered under our Limited Lifetime Warranty.

Fabtech does not warrant any product for finish, alterations, modifications and/or installation contrary to Fabtech's instructions. Alterations to the finish of the parts including but not limited to painting, powdercoating, plating and/or welding will void all warranties. Some finish damage may occur to parts during shipping which is considered normal and is not covered under warranty.

Fabtech products are not designed nor intended to be installed on vehicles used in race applications or for racing purposes or for similar activities. (A "RACE" is defined as any contest between two or more vehicles, or any contest of one or more vehicle against the clock, whether or not such contest is for a prize). This warranty does not include coverage for police or taxi vehicles, race vehicles, or vehicles used for government or commercial purposes. Also excluded from this warranty are sales outside of the United States of America.

Installation of most suspension products will raise the center of gravity of the vehicle and will cause the vehicle to handle differently than stock. It may increase the vehicle's susceptibility to a rollover, on road and off road, at all speeds. Extreme care should be taken to operate the vehicle safely at all times to prevent rollover or loss of control resulting in serious injury or death. Fabtech front end Desert Guards may impair the deployment or operation of vehicles equipped with supplemental restraining systems/air bag systems and should not be installed if the vehicle is equipped as so.

Fabtech makes every effort to ensure suspension product compatibility with all vehicles listed in the catalog, but due to unknown auto manufacturers production changes and/or inconsistencies by the auto manufacturer, Fabtech cannot be responsible for 100% compatibility, including the fitment of tire and wheel sizes listed. The Tire and Wheel sizes listed in Fabtech's catalog are only a guideline for street driving with noted fender trimming. Fabtech is not responsible for damages to the vehicle's body or tires.

Fabtech's obligation under this warranty is limited to the repair or replacement, at Fabtech option, of the defective product only. All costs of removal, installation or re-installation, freight charges, incidental or consequential damages are expressly excluded from this warranty. Fabtech is not responsible for damages and/or warranty of other vehicle parts related or non related to the installed Fabtech product. This warranty is expressly in lieu of all other warranties expressed or implied. This warranty shall not apply to any product that has been subject to accident, negligence, alteration, abuse or misuse as determined by Fabtech.

Fabtech suspension components must be installed as a complete system including shocks as shown in our current catalog. All warranties will become void if Fabtech parts are combined and/or substituted with other aftermarket suspension products. Combination and/or substitution of other aftermarket suspension parts may cause premature wear and/or product failure resulting in an accident causing injury or death. Fabtech does not warrant products not manufactured by Fabtech.

Installation of Fabtech product may void the vehicles factory warranty; it is the consumer's responsibility to check with their local vehicle's dealer for warranty disposition before the installation of the product.

It is the responsibility of the distributor and/or the retailer to review all warranties and warnings of Fabtech products with the consumer prior to purchase.

Fabtech reserves the right to supercede, discontinue, change the design, finish, part number and, or application of parts when deemed necessary without written notice. Fabtech is not responsible for misprints or typographical errors within the catalog or price sheet.