



## **INSTALLATION INSTRUCTIONS**

# **2014-2022 DODGE RAM 2500/3500 5-7" 4.0 DLSS CONVERSION KIT**

**FT23119i**

**NOTE: THIS KIT REQUIRES WELDING**

**Fabtech Motorsports** | 4331 Eucalyptus Ave. Chino, CA 91710

**Tech Line:** 909-597-7800 | **Fax:** 909-597-7185 | **Web:** [www.fabtechmotorsports.com](http://www.fabtechmotorsports.com)

## - PARTS LIST - 4.0 DLSS CONVERSION KIT

<b>FTS23119 COMPONENT BOX 1</b>		
1	FT44390BK	RESI MOUNT (DRIVER)
1	FT44391BK	RESI MOUNT (PASSENGER)
1	FT44314	ABS RELOCATION BRACKET (DRIVER)
1	FT44311BK	UPPER COIL OVER MOUNT (DRIVER)
1	FT44312BK	UPPER COIL OVER MOUNT (PASSENGER)
1	FT44394BK	UPPER BACKING PLATE (DRIVER)
1	FT44395BK	UPPER BACKING PLATE (PASSENGER)
1	FT44424	HARDWARE SUBASSEMBLY
1	FT44422	HARDWARE SUBASSEMBLY
1	FT44423	HARDWARE KIT

<b>FT44422 HARDWARE SUBASSEMBLY</b>		
4	FT89016	#64 HOSE CLAMP 3-9/16 - 4-1/2
2	FT44389	NUT TAB (LOWER MOUNT)
1	FT44388	NUT TAB (UPPER MOUNT)
2	FT44045	NUT TAB
1	FT44408	SPACER SLEEVE 1.00 X .625 X 2.035
1	FT23119i	INSTRUCTIONS
1	FTAS12	STICKER FT BLUE 10X4 DIE CUT
1	FTAS16	DRIVER WARNING DECAL
1	FTREGCARD	REGISTRATION CARD

<b>FT44424 HARDWARE SUBASSEMBLY</b>		
1	FT44381	DRIVER OUTER GUSSET
1	FT44382	DRIVER INNER GUSSET
1	FT44383	PASSENGER OUTER GUSSET
1	FT44384	PASSENGER INNER GUSSET
1	FT44385	SPACING TOOL
1	FT44386	DRIVER TOP GUSSET
1	FT44387	PASSENGER TOP GUSSET

<b>FT44423 - HARDWARE KIT</b>		<b>LOCATION</b>
10	7/16-14 X 1-1/2 HEX BOLT G8	
2	7/16 SPLIT LOCK WASHER	
1	7/16-14 X 1-1/4 HEX BOLT G8	
2	7/16 USS WASHER G8	
20	7/16 SAE WASHER G8	
9	7/16-14 C-LOCK NUT	
2	5/8-11 X 3-1/4 HEX BOLT G8	
2	5/8 SAE WASHER G8	
2	5/8-11 X 4 SOCKET HD BOLT	
2	5/8-11 C-LOCK NUT	
4	5/8 SAE WASHER	
2	3/8-16 X 1-1/4 HEX BOLT	
2	3/8-16 C-LOCK NUT	
4	3/8 SAE WASHER	
2	1/4-20 X 1 HEX BOLT	
2	1/4-20 NYLOCK NUT	
4	SAE WASHER	
1	THREAD LOCKING COMPOUND	

## **- TOOL LIST -**

### ***Required Tools (Not Included)***

- Basic Hand Tools
- Floor Jack
- Jack Stands
- Assorted Metric and S.A.E sockets, and Allen
- Wrenches
- Torque Wrench
- Die Grinder w/ Cutoff Wheel or Sawzall
- Welder
- Barrel Sander
- Drill w/ assorted drill bits
- Black spray paint

## **- PRE-INSTALLATION NOTES -**

For technical assistance call: **909-597-7800** or e-mail: **info@fabtechmotorsports.com**

### ***READ THIS BEFORE YOU BEGIN INSTALLATION -***

Check all parts to the parts list above before beginning installation. If any parts are missing contact Fabtech at 909-597-7800 and a replacement part will be sent to you immediately.

Read all instructions thoroughly from start to finish before beginning the installation. If these instructions are not properly followed severe frame, driveline and / or suspension damage may occur.

Check your local city and state laws prior to the installation of this system for legality. Do not install if not legal in your area.

Prior to the installation of this suspension system perform a front end alignment and record. Do not install this system if the vehicle alignment is not within factory specifications. Check for frame and suspension damage prior to installation.

The installation of this suspension system should be performed by two professional mechanics.

This suspension must be installed with Fabtech shock absorbers.

Installation of all fasteners requires the use of provided thread locking compound with proper torque values as indicated throughout the installation. Apply thread locking compound upon the final torque of the fastener.

**WARNING-** Installation of this system will alter the center of gravity of the vehicle and may increase roll over as compared to stock.

Vehicles that receive oversized tires should check ball joints, uniballs, tie rods ends, pitman arm and idler arm every 2500-5000 miles for wear and replace as needed.

Verify differential fluid is at manufactures recommended level prior to kit installation. Installation of the kit will reposition the differential and the fill plug hole may be in a different position. (For example, if the manufacture recommends 3 quarts of fluid, make sure the diff has 3 quarts of fluid). Check your specific manual for correct amount of fluid.

### ***FOOTNOTES -***

- Does not fit power wagon models
- Will not fit gas model vehicles
- Does not fit dually models.

## **- IMPORTANT NOTICE -**

***This Coilover Conversion requires critical welding for installation that must be performed by a professional certified welder. The weld on Coilover axle mounts will support the entire vehicle and therefore requires proper weld penetration and uniformity to ensure safety.***

# - INSTRUCTIONS -

## FRONT SUSPENSION

1. Disconnect the negative terminal on the battery. Jack up the front end of the truck and support the frame rails with jack stands. **NEVER WORK UNDER AN UNSUPPORTED VEHICLE!** Remove the front tires.
2. Supporting the front axle, disconnect the track bar, sway bar end links and brake lines brackets from the axle housing. Remove shocks, coil springs, and rubber isolators.
3. Unbolt the ABS control box (2 front bolts, 1 back side bolt) from the bracket on the top of the drivers side upper coil spring mount. Locate the cut-out template on page 13. Using the template on the upper coil spring mount, mark the outer diameter and cut. Using a barrel sander, sand edges to a smooth finish. **SEE FIGURE 1-2**

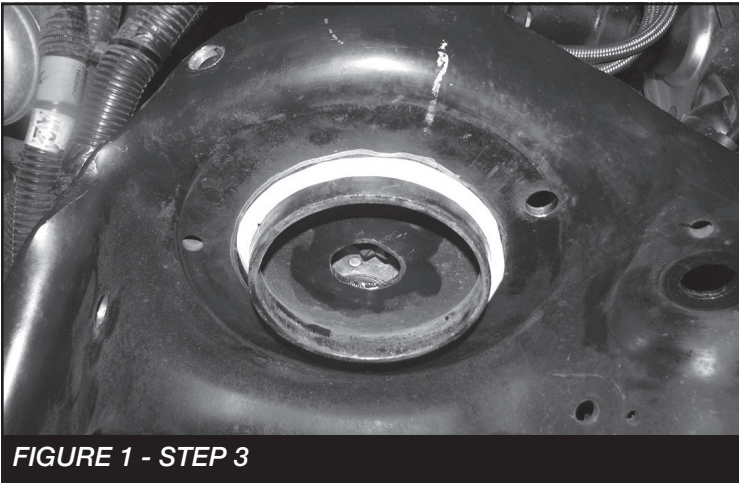

FIGURE 1 - STEP 3



FIGURE 2 - STEP 3

4. Using a cut off wheel, cut the factory ABS bracket off the upper coil spring perch. Remove the 2 bushings and save for later. **SEE FIGURE 3-4**

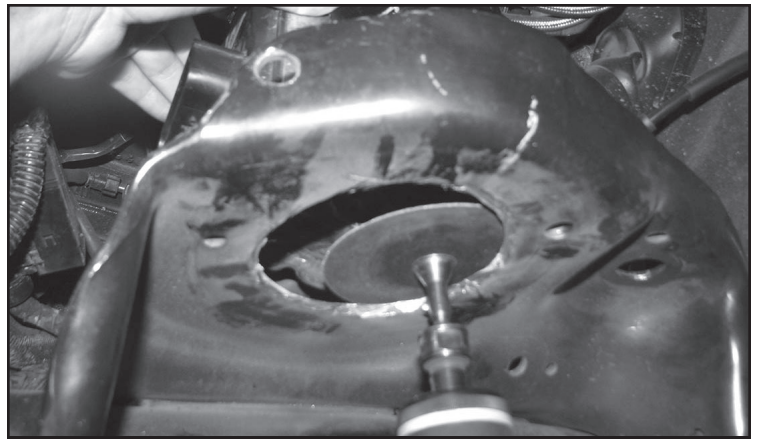

FIGURE 3 - STEP 4

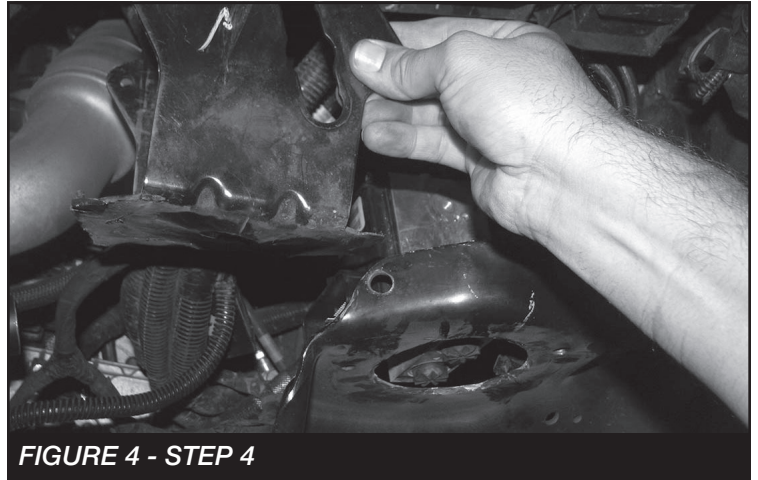

FIGURE 4 - STEP 4

5. Locate FT44311BK (Driver Coilover Bracket), FT44394BK (Driver Backing Plate) and 7/16" hardware. Using (1) 7/16" bolt and nut. Mount the FT44311BK (Coilover bracket) using the existing hole and mark the other front outside hole from the top. Also, mark the side hole for drilling. Remove the FT44394BK (Coilover bracket) and drill the previous marked holes to 1/2". **SEE FIGURES 5-8**

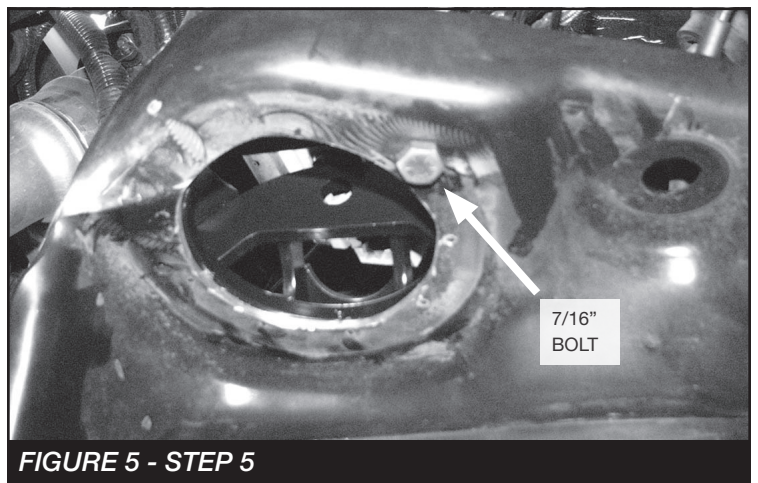

FIGURE 5 - STEP 5

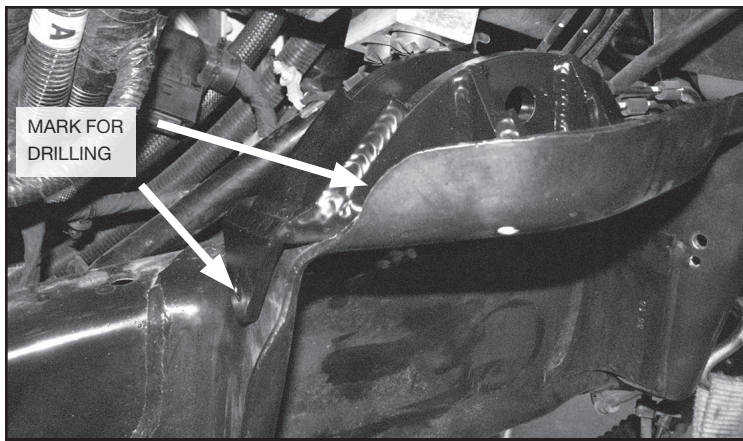

FIGURE 6 - STEP 5

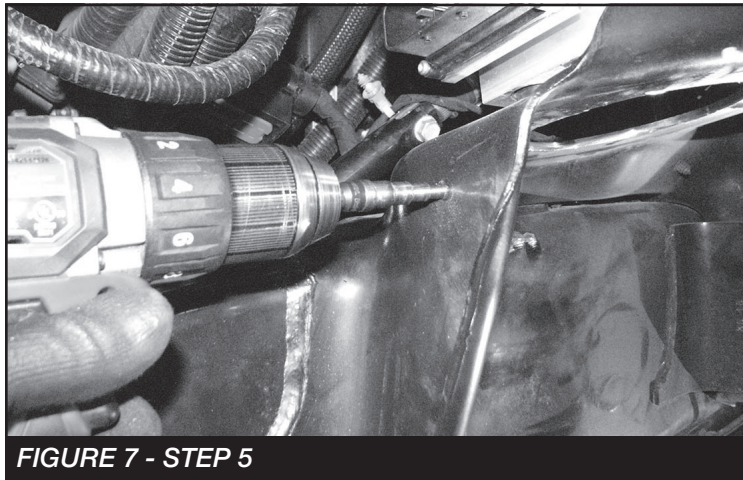

FIGURE 7 - STEP 5

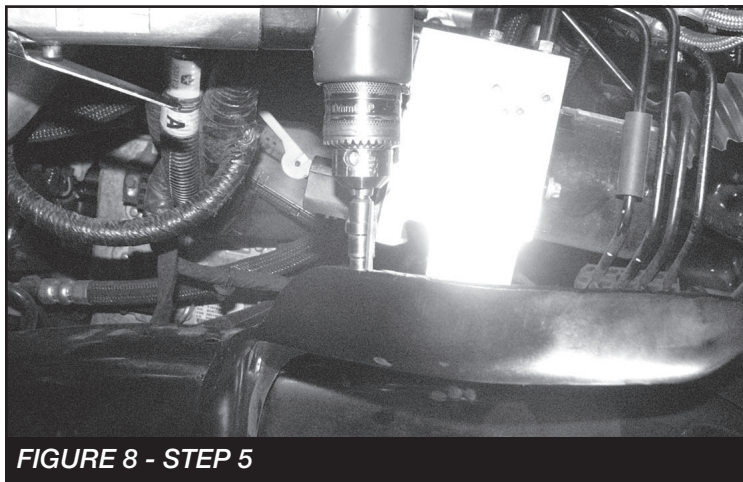

FIGURE 8 - STEP 5

6. Next, install the FT44394BK (Upper backing plate) with (2) 7/16" bolts and hardware and mark/drill the inside holes to 1/2". **NOTE: Use caution not to drill into the ABS actuator unit.** Remove the FT44394 and paint bare surfaces. **SEE FIGURES 9-10**



FIGURE 9 - STEP 6

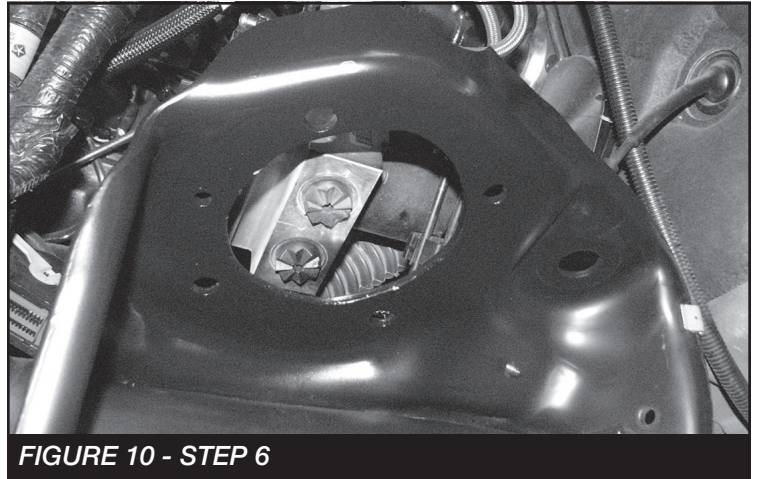

FIGURE 10 - STEP 6

7. Repeat steps 3-6 on the passenger side using FT44312BK and FT44395BK. **NOTE: Passenger side does not have ABS unit or bracket to be removed.**

8. The lower coil spring perch will need to be removed. Mark and cut at the factory welds on all 4 sides. **SEE FIGURES 11-12.**

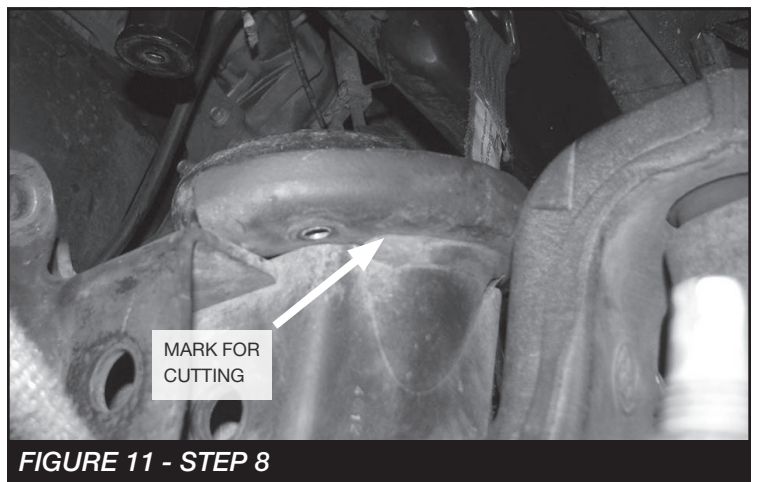

FIGURE 11 - STEP 8

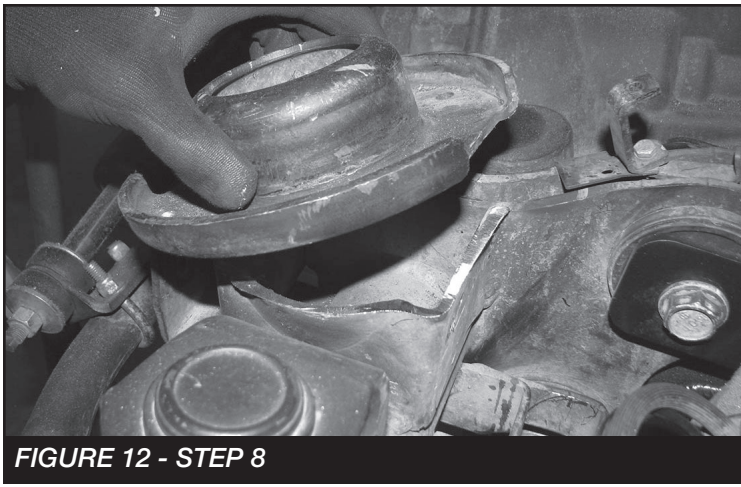

FIGURE 12 - STEP 8

9. Once the lower coil spring perch has been removed, locate the back of the axle bracket and mark from the bottom 3.25" (outside) and 2.75" (inside). Cut and sand to a smooth finish. **SEE FIGURE 13**

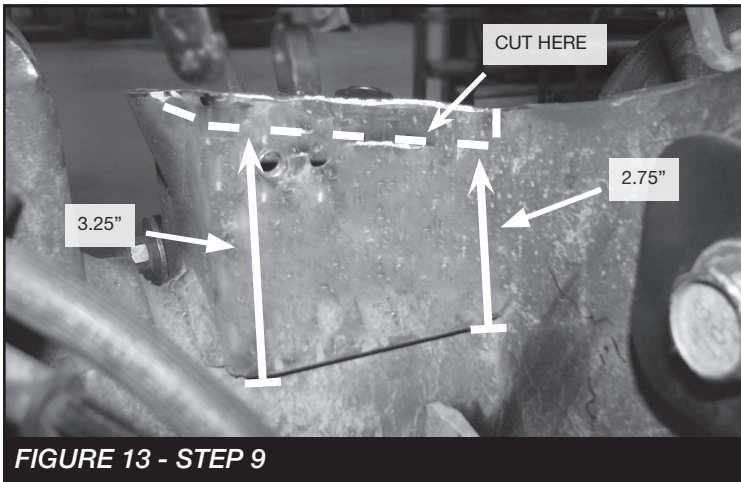

FIGURE 13 - STEP 9

10. On the inside of the spring perch support, measure 1.25" from the front and mark, next measure 2.25" from that mark. Measure 2.375" from the front, from there measure 1.25" down and mark. Radius the 3 marks like shown in **FIGURE 14**. Carefully cut the support. **NOTE: Cutting will need to be done to both plates, the one you marked and the one behind.** **SEE FIGURE 15**. Sand to a smooth finish.

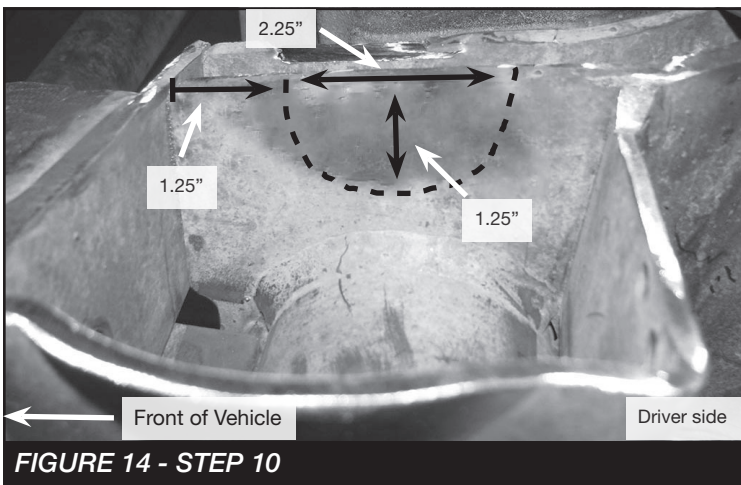

FIGURE 14 - STEP 10



FIGURE 15 - STEP 10

11. **(DRIVER SIDE)** Locate the 5/8" X 3-1/4" bolt. Install the following parts in order. FT44385 (spacing tool), FT44382 (driver inner gusset), FT44408 (spacer sleeve) and FT44381 (driver outer gusset), washer and nut. **SEE FIGURES 16-20**

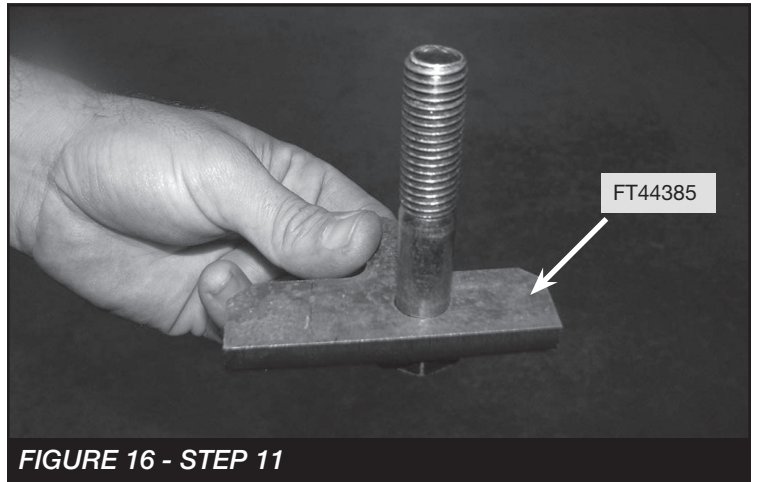

FIGURE 16 - STEP 11

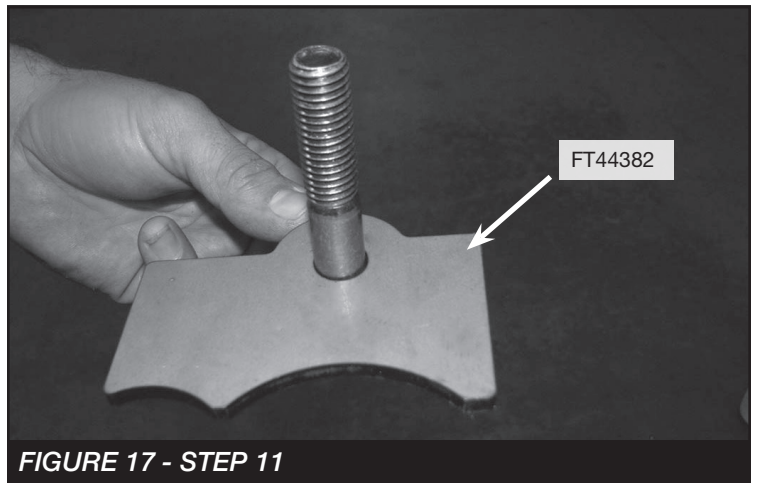

FIGURE 17 - STEP 11

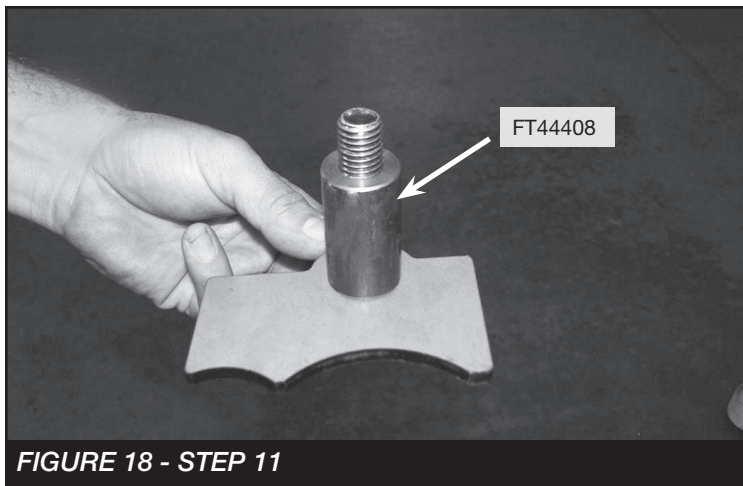

FIGURE 18 - STEP 11

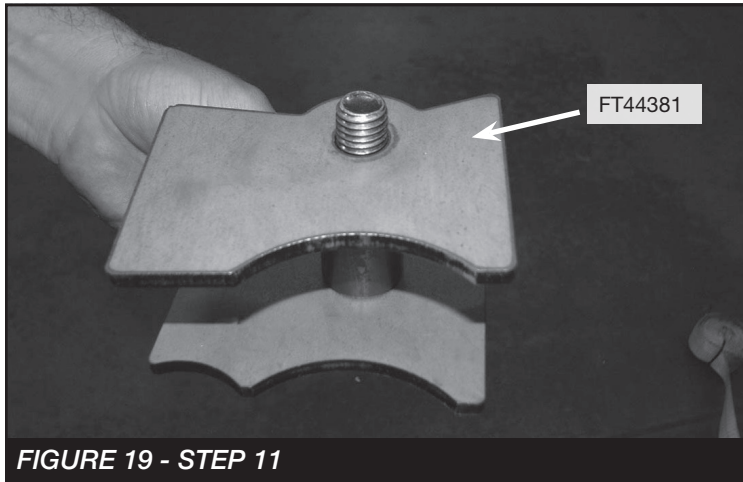

FIGURE 19 - STEP 11

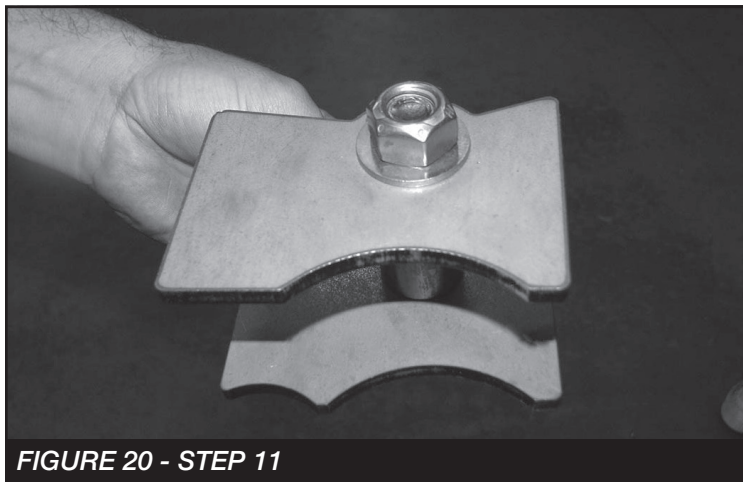

FIGURE 20 - STEP 11

12. **NOTE: Clean the inside of the spring perch support and axle tube, prep for welding.** Install the assembly in the spring perch support and tack weld only the FT44382 (inner gusset) and FT44381 (outer gusset). Next, remove the 5/8" bolt, FT44385 (spacing tool) and FT44408 (spacing sleeve) and save for passenger side installation. **SEE FIGURES 21-22**

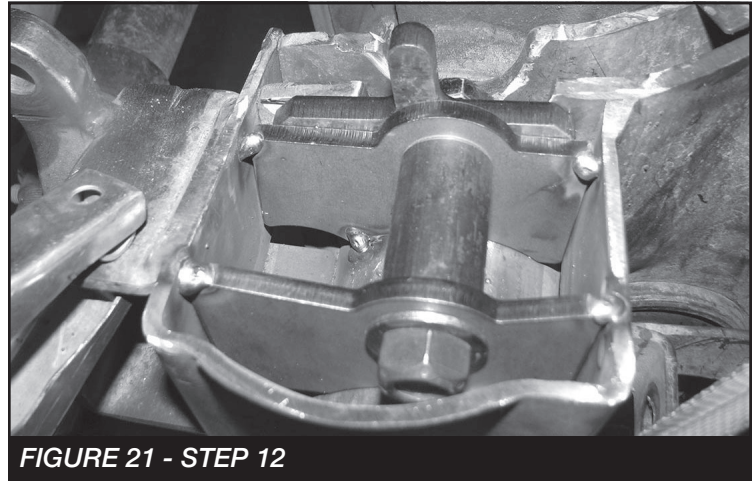

FIGURE 21 - STEP 12

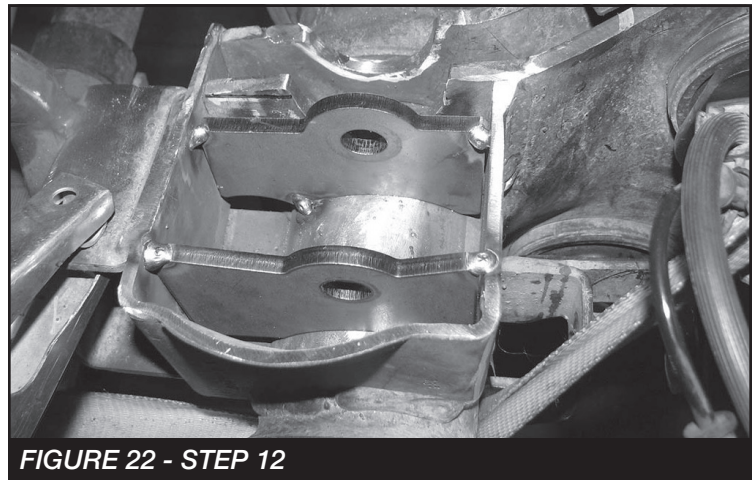

FIGURE 22 - STEP 12

13. **NOTE: THIS STEP IS TO BE PERFORMED BY A CERTIFIED WELDING TECHNICIAN ONLY!!!** Weld the gussets into the spring perch support and to the axle tube. **SEE FIGURE 23**

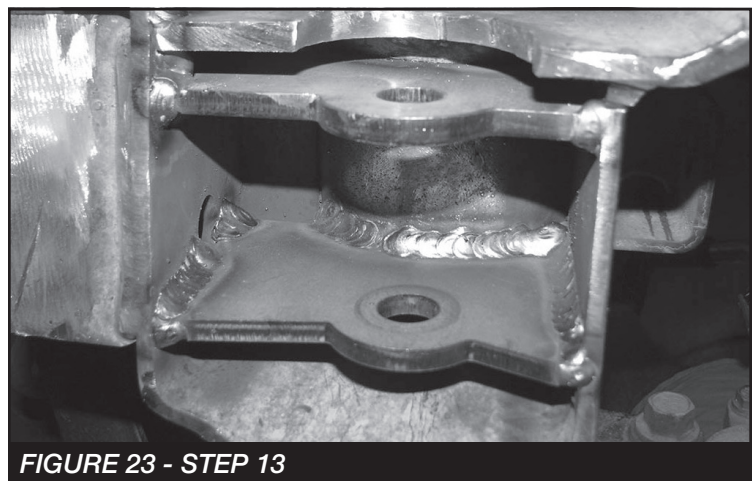

FIGURE 23 - STEP 13

14. Locate FT44386 (driver top gusset) and tack weld into place. **SEE FIGURE 24.** Next, weld the top gusset completely in, then paint all raw parts. **SEE FIGURE 25**

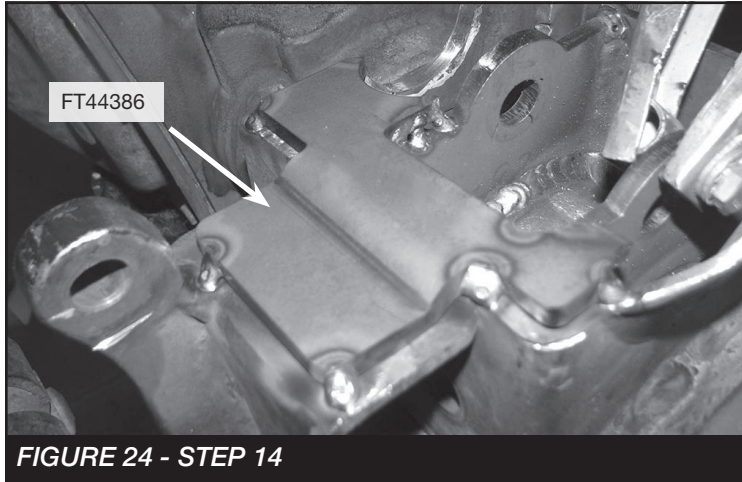

FIGURE 24 - STEP 14



FIGURE 25 - STEP 14

- REPEAT STEPS 8-10 ON PASSENER SIDE.

15. Locate the 5/8" x 3-1/4" bolt. Install in the following order: FT44385 (spacing tool), FT44384 (passenger inner gusset), FT44408 (spacing sleeve), FT44383 (passenger outer gusset), washer and nut. **SEE FIGURE 26**

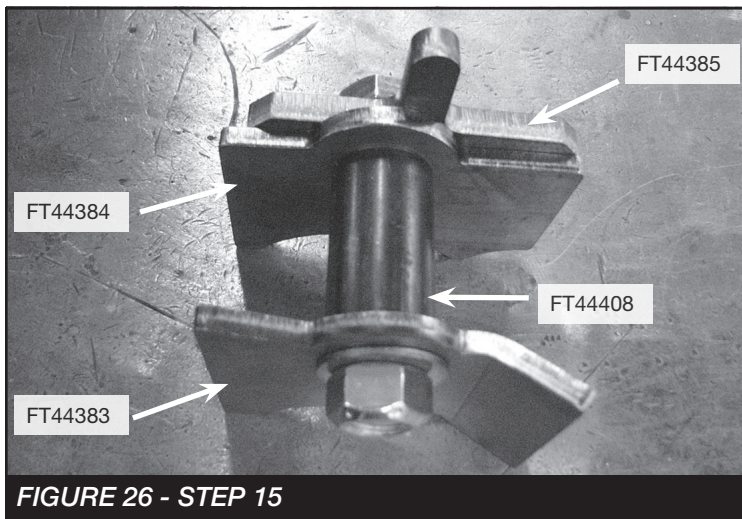

FIGURE 26 - STEP 15

16. Install the assembly into the passenger side spring perch support and tack weld FT44384 (inner gusset) and FT44383 (outer gusset). Remove and save the 5/8" hardware. You can discard the FT44385 (spacing tool) and FT44408 (spacing sleeve). **Completely weld the gussets into the spring perch support and axle tube. SEE FIGURE 27-28**

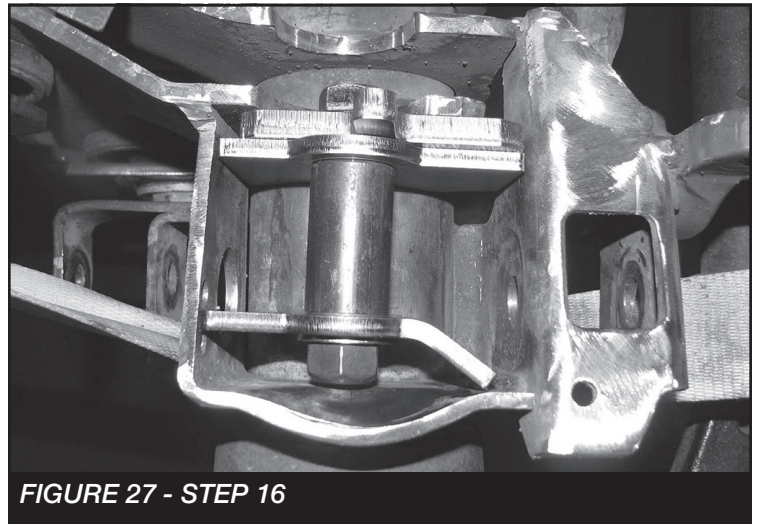

FIGURE 27 - STEP 16

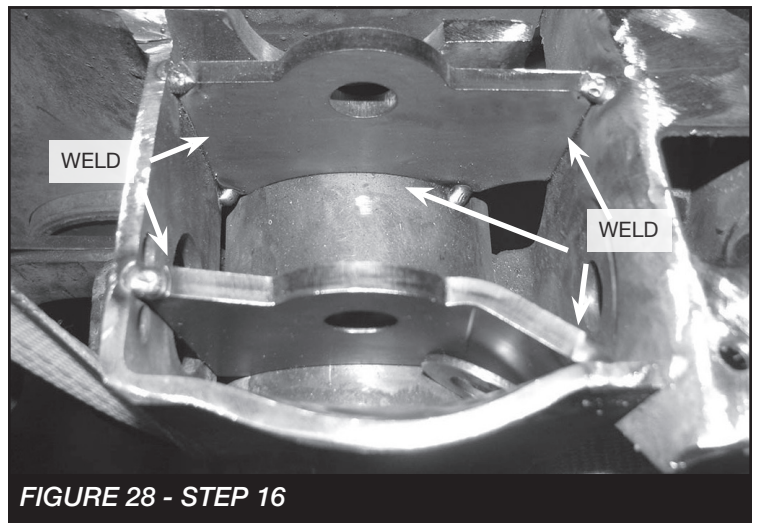

FIGURE 28 - STEP 16



17. Locate FT44387 (Passenger top gusset) and tack weld into place. **SEE FIGURE 29.** Next, weld the top gusset completely in, then paint all raw parts.



18. **(DRIVER SIDE)** Locate FTS835102 or FTS835122 (4.0 Dirt Logic Coilover), and FT44394BK (driver upper backing plate). **NOTE: Avoid scratching the reservoir can by taping it up.** **NOTE: USE EXTRA CARE WITH THE RESI HOSE AND FITTINGS WHEN INSTALLING.** Using the help of another person. Install the FT44394BK (backing plate) onto the top of the coilover by installing the resi through it. Next, carefully install the resi through the hole previously opened up on the upper spring mount. **SEE FIGURE 30-31**

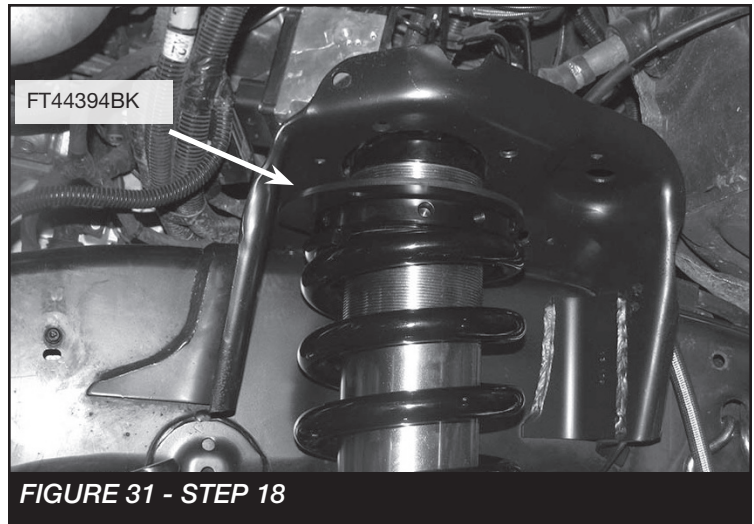
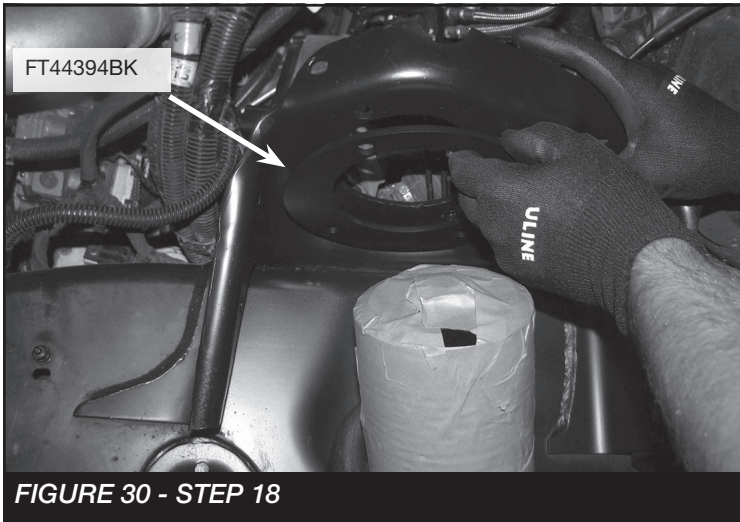

19. Locate and install the misalignments into the top of the coilover. Install the FT44311BK (upper coilover mount driver) and FT44314 (ABS Bracket) to the Fabtech coilover using the supplied 5/8" x 4" button head bolt and hardware. **LEAVE LOOSE.** **NOTE: The resi hose needs to be oriented towards the rear of the vehicle.** **SEE FIGURE 32**

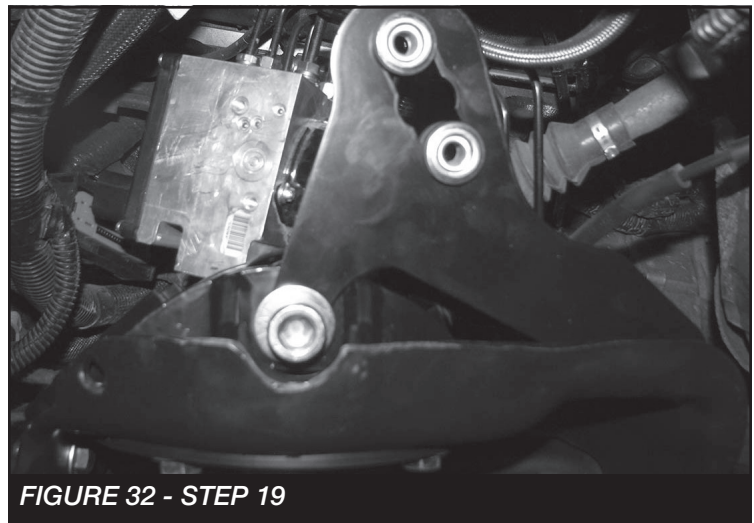

20. Install the supplied (4) 7/16" x 1-1/2" hardware from the bottom of the mount. **NOTE: Use (2) FT44045 (nut tab) for the outer holes.** Torque to 83 ft-lbs. **SEE FIGURES 33-34**

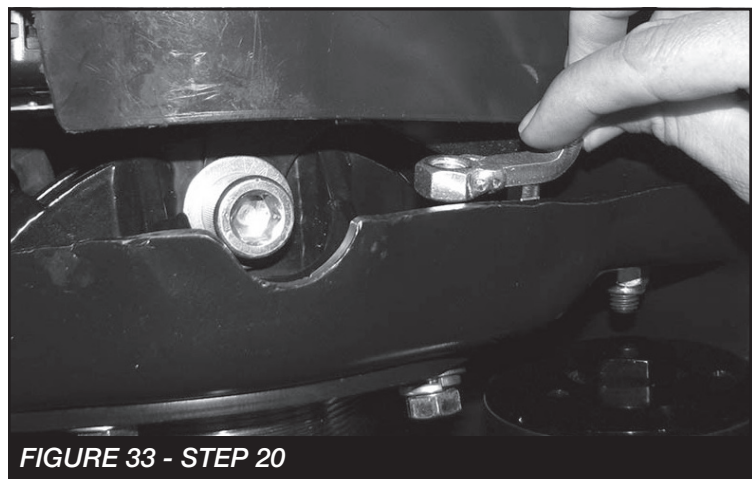

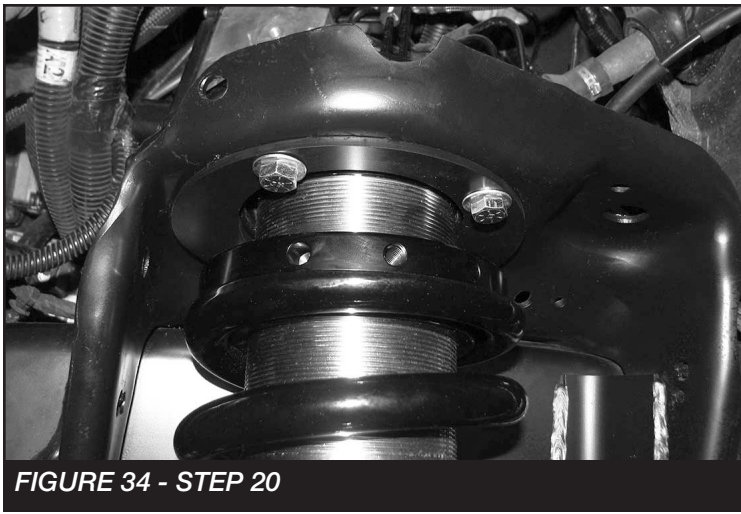

FIGURE 34 - STEP 20

21. Install the 7/16" x 1-1/4" bolt, 7/16" USS washers and nut through the ABS bracket and the hole where the factory shock was located. Torque to 83 ft-lbs. Next, Torque the 5/8" bolt to 179 ft-lbs. **SEE FIGURES 35**



FIGURE 35 - STEP 21

22. Install the factory bushings into the new Fabtech ABS bracket that were removed in Step 4. Reinstall the ABS actuator with the factory bolts. **SEE FIGURE 36**

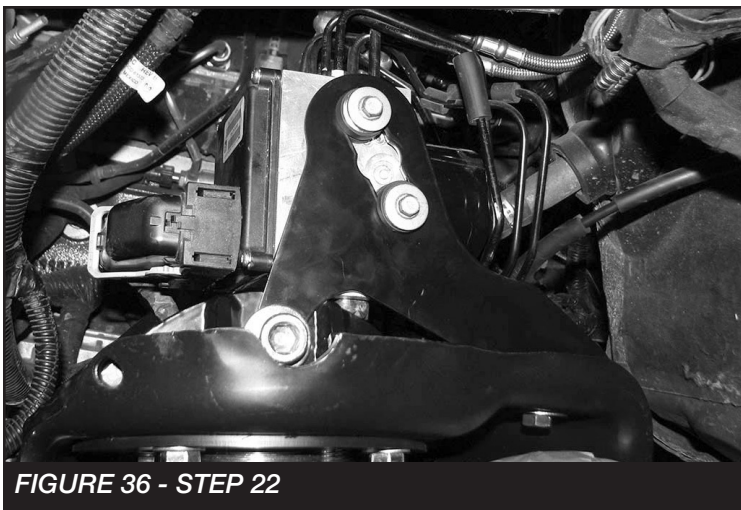

FIGURE 36 - STEP 22

23. Install the misalignment spacers onto the coilover and install the into the axle mount using the supplied 5/8" x 3-1/4" bolt, washers and FT44389 (Nut Tab). Torque to 179 ft-lbs **SEE FIGURE 37**



FIGURE 37 - STEP 23

24. Locate the existing holes on the factory coil bucket. Drill the top hole out to 3/8". Install the FT44390BK (Resi Mount Driver) using the supplied 3/8" x 1-1/4" and 1/4" x 1" hardware. **SEE FIGURES 38-39**

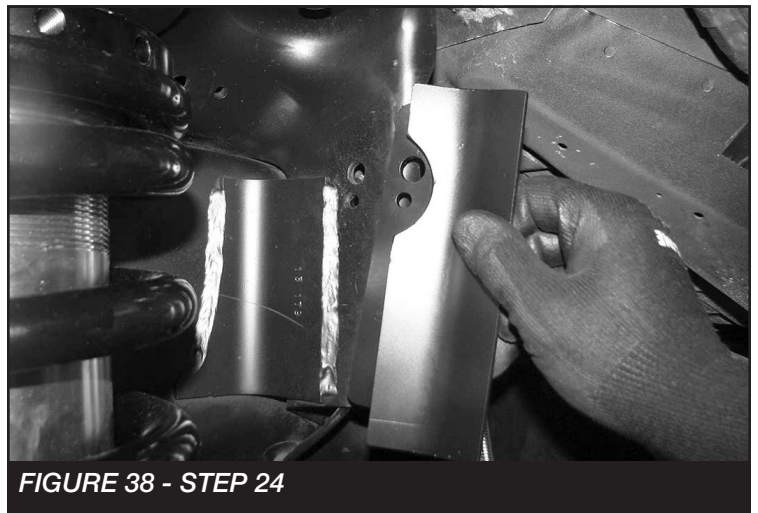
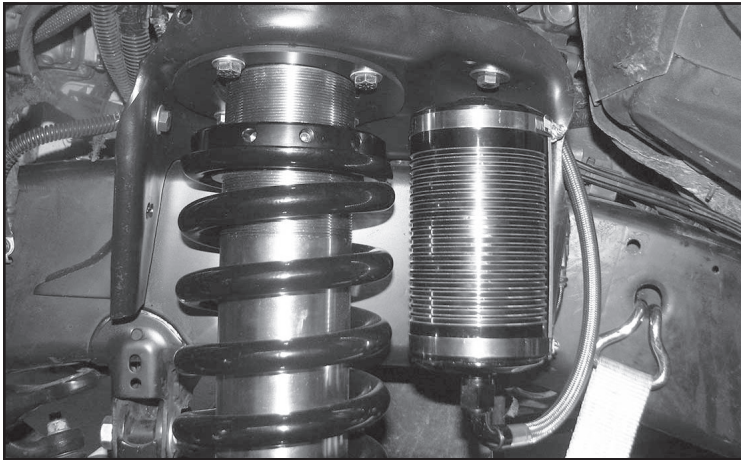

FIGURE 38 - STEP 24



FIGURE 39 - STEP 24

25. Install the coilover Resi to the Resi mount using the supplied hose clamps. **SEE FIGURE 40**



**FIGURE 40 - STEP 25**

- **REPEAT STEPS 18-25 ON THE PASSENGER SIDE. NOTE: Disregard steps pertaining to the ABS bracket.**
26. When installing the 5/8" x 4" Socket Head bolt on the passenger side upper coilover mount. Use FT44388 (Nut Tab).
27. Before installing the track bar to the axle. The factory nut tab will need to be to cut. Trim 1-1/2" off the end and reinstall. **SEE FIGURE 41**

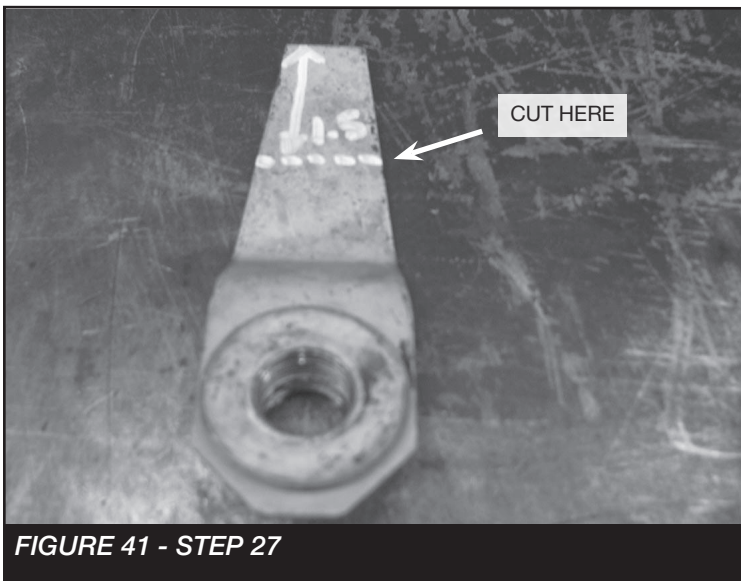

**FIGURE 41 - STEP 27**

28. Reinstall inner fender liners.
29. Install tires and wheels and torque lug nuts to wheel manufacturer's specifications. Turn front tires left to right and check for appropriate tire clearance. **Note - Some oversized tires may require trimming of the front bumper & valance.**
30. Check front end alignment and set to factory specifications. Readjust headlights.
31. Recheck all bolts for proper torque.

32. Recheck brake hoses, ABS wires and suspension parts for proper tire clearance while turning tires fully left to right.
33. Check the fluid in the front and rear differential and fill if needed with factory specification differential oil. **Note - some differentials may expel fluid after filling and driving. This can be normal in resetting the fluid level with the new position of the differential/s.**
34. Install Driver Warning Decal. Complete product registration card and mail to Fabtech in order to receive future safety and technical bulletins on this suspension.

**Vehicles that will receive oversized tires should check ball joints, uniballs and all steering components every 2500-5000 miles for wear and replace as required.**

**RE-TORQUE ALL NUTS, BOLTS AND LUGS AFTER 50 MILES AND PERIODICALLY THEREAFTER.**

For technical assistance call: **909-597-7800**



# 4.0 COILOVER CONVERSION TEMPLATE

PRINT AT 100% - DO NOT SCALE TO PAGE

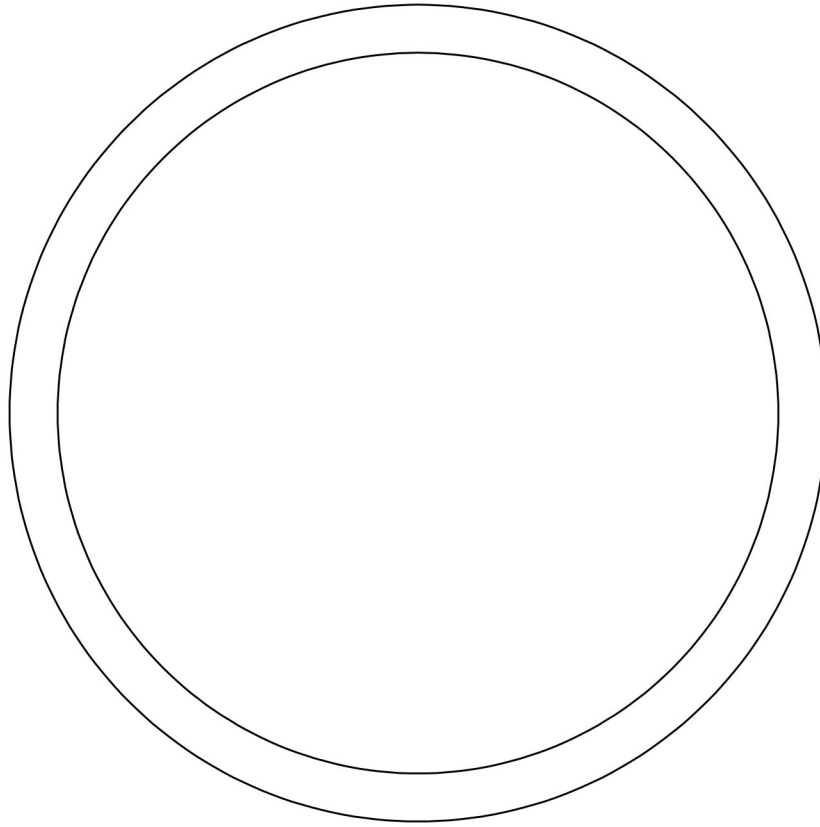



## - Product Warranty and Warnings -

Fabtech provides a Limited Lifetime Warranty to the original retail purchaser who owns the vehicle, on which the product was originally installed, for defects in workmanship and materials.

The Limited Lifetime Warranty excludes the following Fabtech items; bushings, bump stops, ball joints, tie rod ends, limiting straps, cross shafts, heim joints and driveshafts. These parts are subject to wear and are not considered defective when worn. They are warranted for 60 days from the date of purchase for defects in workmanship.

Dirt Logic and Performance Coilover take apart shocks are considered a serviceable shock with a one year warranty on leakage only. Service seal kits are available separately for future maintenance. All other shocks are covered under our Limited Lifetime Warranty.

Fabtech does not warrant any product for finish, alterations, modifications and/or installation contrary to Fabtech's instructions. Alterations to the finish of the parts including but not limited to painting, powder coating, plating and/or welding will void all warranties. Some finish damage may occur to parts during shipping, which is considered normal and is not covered under warranty.

Fabtech products are not designed nor intended to be installed on vehicles used in race applications or for racing purposes or for similar activities. (A "RACE" is defined as any contest between two or more vehicles, or any contest of one or more vehicle against the clock, whether or not such contest is for a prize). This warranty does not include coverage for police or taxi vehicles, race vehicles, or vehicles used for government or commercial purposes. Also excluded from this warranty are sales outside of the United States of America.

Installation of most suspension products will raise the center of gravity of the vehicle and will cause the vehicle to handle differently than stock. It may increase the vehicle's susceptibility to a rollover, on road and off road, at all speeds. Extreme care should be taken to operate the vehicle safely at all times to prevent rollover or loss of control resulting in serious injury or death. Fabtech front end Desert Guards may impair the deployment or operation of vehicles equipped with supplemental restraining systems/air bag systems and should not be installed if the vehicle is equipped as so.

Fabtech makes every effort to ensure suspension product compatibility with all vehicles listed on the website, but due to unknown auto manufacturer's production changes and/or inconsistencies by the auto manufacturer, Fabtech cannot be responsible for 100% compatibility, including the fitment of tire and wheel sizes listed. The Tire and Wheel sizes listed in Fabtech's website are only a guideline for street driving with noted fender trimming. Fabtech is not responsible for damages to the vehicle's body or tires. Fabtech is not responsible for premature wear of factory components due to the installation of oversized tires and wheels.

Fabtech's obligation under this warranty is limited to the repair or replacement, at Fabtech option, of the defective product only. All costs of removal, installation or re-installation, freight charges, incidental or consequential damages are expressly excluded from this warranty. Fabtech is not responsible for damages and/or warranty of other vehicle parts related or non related to the installed Fabtech product. This warranty is expressly in lieu of all other warranties expressed or implied. This warranty shall not apply to any product that has been subject to accident, negligence, alteration, abuse or misuse as determined by Fabtech.

Fabtech suspension components must be installed as a complete system including shocks as shown on our website. All warranties will become void if Fabtech parts are combined and/or substituted with other aftermarket suspension products. Combination and/or substitution of other aftermarket suspension parts may cause premature wear and/or product failure resulting in an accident causing injury or death. Fabtech does not warrant products not manufactured by Fabtech.

Depending on the condition of the factory suspension components retained after the installation of a Fabtech suspension not all vehicles may have the same ride stance front to rear as described in the website. The blue color of suspension components shown in all Fabtech photographs are for display purposes only. Majority of all Fabtech components will be black specifically where noted with part numbers ending in BK.

Installation of Fabtech product may void the vehicles factory warranty; it is the consumer's responsibility to check with their local vehicle's dealer for warranty disposition before the installation of the product. Some state laws may prohibit modification of suspension to a vehicle in whole or in part. It is the responsibility of the installer and consumer to consult local laws prior to the installation of any Fabtech suspension product to comply with such written laws.

It is the responsibility of the distributor and/or the retailer to review all warranties and warnings of Fabtech products with the consumer prior to purchase.

Fabtech reserves the right to super cede, discontinue, change the design, finish, part number and/or application of parts when deemed necessary without written notice. Fabtech is not responsible for misprints or typographical errors within the website or price sheet. For the most recent Product Warranty and Warnings visit our website [www.fabtechmotorsports.com](http://www.fabtechmotorsports.com)