



## *Installation Instructions*



### *Jeep TJ Long Arm Suspension System*

*1997-2002 JEEP TJ 4WD*

**Fabtech Motorsports 4331 Eucalyptus Ave. Chino, CA 91710**  
**Tech Line 909-597-7800 Fax 909-597-7185 Web [www.fabtechmotorsports.com](http://www.fabtechmotorsports.com)**



[www.fabtechmotorsports.com](http://www.fabtechmotorsports.com)

**6" 1997-2002 JEEP TJ 4WD**  
**FTS24002 & BK / FTS24003 & BK / FTS44002 & BK**  
**PARTS LIST**

<b>FTS24002BK</b>			<b>Jeep TJ 6' Box Kit 1</b>		
<b>Qty</b>	<b>Part #</b>	<b>Description</b>			
2	FT50013	Frt Sway Bar Bracket upper			
1	FT50036	Frt Sway Bar Brk. Lower Drv.			
1	FT50066	Frt Sway Bar Brk. Lower Pass.			
1	FT50070BK	6" / 8" Frt Sway Bar Link Drv			
1	FT50071BK	6" / 8" Frt Sway Bar Link Pass			
1	FT50323	Hdwr Sub-Assembly			
4	FT50027	Urethane Bump Stop			
2	FT50030BK	Front Lower Links			
2	FT50031BK	Front Upper Links			
2	FT50032BK	Rear Lower Links			
1	FT50061BK	Rear Upper Link Pass			
1	FT50033BK	Rear Upper Link Drv			

<b>FT50323</b>			<b>Hdwr Sub-Assembly Kit</b>		
<b>Qty</b>	<b>Part #</b>	<b>Description</b>			
2	FT50034	Front Brake Hose			
1	FT50035	Rear Brake Hose			
3	FT50055	Brake Hose Bracket			
3	FTT79	Brake line Clip			
4	FT44516	Crush Washers			
1	FT50063	TC Shift Bracket			
2	FT50067	Sway Bar link Frame Bracket			
2	FT42	Sway Bar Pin			
2	FT90036	Lynch Pin			
2	FT45	Sway Bar Key Ring 1 1/2"			

<b>FTS24003BK</b>			<b>TJ 6" Box Kit 2</b>		
<b>Qty</b>	<b>Part #</b>	<b>Description</b>			
1	FT50029BK	Extended Front Trac Bar			
2	FTS98000	3/4" Heim			
4	FT43	Heim Misalignments			
1	FT97150-6-106	3/8 Spacer			
1	FT81	Frt. Trac Bar Upper Sleeve			
2	FT30	Rod End			
1	FT50097	Nut Tab Frt Trac Bar			
1	FT50015	Pitman Arm			
1	FT50038	E Brake Cable Extension			
1	FT50039BK	Extended Rear Trac Bar			
2	FT50037BK	Rear Sway Bar Links			
1	FT50044BK	Link Sub Frame Pass			
1	FT50045BK	Link Sub Frame Drv			
1	FT50049	Hardware Kit			
1	FT50050	Hardware Kit			
1	FT50051	Bushing Kit			
1	FT50089	Sleeve Kit Front Sway Bar			
1	FT50092	Sleeve Kit Rear Sway Bar			
4	FT50052	Alum Bump Stop			
1	FT50053BK	Rear Axle Trac Bracket			
1	FT46	Sleeve RR Frame Trac Bracket			
1	FT50054BK	Rear Frame Trac Bracket			
1	FT50056	Rear Axle Shock Mount (DRV)			
1	FT50057	Rear Axle Shock Mount (PASS)			
1	FT50058	Frame Tab Nut Front DRV			
1	FT50059	Frame Tab Nut Front PASS			
4	FT50060	Frame Tab Nut Center			
2	FT50062	Bump Stop Spacer Rear Upper			



[www.fabtechmotorsports.com](http://www.fabtechmotorsports.com)

**6" 1997-2002 JEEP TJ 4WD  
FTS24002 & BK / FTS24003 & BK / FTS44002 & BK  
HARDWARE LIST:**

<b>FT50049 Hardware Kit</b>	
<b>Qty</b>	<b>Description</b>
6	1/2"-13 X 1 1/2" Button Head Bolt
6	1/2"-13 X 3 1/2" Bolt
2	9/16"-12 X 5" Bolt
4	7/16"-14 X 3" Bolt
2	9/16"-12 X 4" Bolt
2	9/16"-12 X 7" Bolt
1	12mm x 1.75mm x 60mm button head
1	1/2"-13 X 4" Bolt
2	3/8"-24 Non Lock Nut
2	3/8"-24 x 1 3/4" Bolt
2	1/4"-20 x 3/4" Bolt
2	1/4"-20 Nyloc Nut
2	1/4" Split Washer
2	1/4" SAE Flat Washer
2	5/16"-18 x 1/2" threading forming bolt
1	5/16"-18 x 1" Bolt
1	5/16"-18 Nylok Nut
4	7/16"-14 C-Lock Nut
6	9/16"-12 C-Lock Nut
1	1/2"-13 C-Lock Nut
1	12mm x 1.75 C-Lock Nut
1	12mm Flat Washer
2	1/2" SAE Flat Washer
6	1/2" USS Flat Washer
8	7/16" SAE Flat Washer
12	9/16" SAE Flat Washer
2	5/16" SAE Flat Washer
14	Grease Fittings
2	Adel Clamp
2	Spring With Round Ends
1	Lock Tight
4	3/4-Fine RH Short Hex Jam Nut

<b>FT50050 Hardware Kit</b>	
<b>Qty</b>	<b>Description</b>
2	1/2"-13 x 1 1/4" Bolt
7	1/2"-13 x 3" Bolt
4	5/16"-18 x 2" Bolt
2	1/2"-13 x 5" Bolt
2	3/8"-16 Nylock Nut
2	3/8" SAE Flat Washer
2	1/4"-20 x 1" Bolt
2	5/16"-18 x 1" Bolt
2	1/2"-13 x 2-3/4" Bolt
2	1/2"-13 x 1-1/2" Bolt
2	5/16"-18 x 1" Self Tapping
2	3/8"-16 Nylock Nut
6	1/2"-13 Nylock Nut
7	1/2"-13 C-Lock Nut
6	5/16"-18 Nylock Nut
2	1/4"-20 Nylock Nut
26	1/2" SAE Flat Washer
12	5/16" SAE Flat Washer
4	1/4" SAE Flat Washer
2	10mm Flat Washer
2	3/8" SAE Flat Washer



[www.fabtechmotorsports.com](http://www.fabtechmotorsports.com)

**6" 1997-2002 JEEP TJ 4WD  
FTS24002 & BK / FTS24003 & BK / FTS44002 & BK**

**DO NOT ALTER THE FINISH OF THESE COMPONENTS, EXAMPLE- CHROMING, ZINC PLATING OR PAINTING. CHANGING THE FINISH CAN CAUSE STRUCTURAL FATIGUE OF COMPONENTS.**

**THIS SUSPENSION SYSTEM MUST BE INSTALLED WITH FABTECH SHOCK ASBORBERS**

**THIS SYSTEM HAS BEEN DESIGNED TO USE 35/1250R15 TIRES WITH 15 X 8 WHEELS W/ 3-3/4" BACKSPACING**

**INSTALLATION OF A FIXED YOKE CV STYLE REAR DRIVESHAFT (NOT INLCUDED) WILL BE REQUIRED WITH THIS SYSTEM TO REDUCE DRIVELINE VIBRATION  
ORDER 1 - FTS94004 & 1 - FTS94005**

**THIS KIT IS DESIGNED TO BE INSTALLED ON A JEEP WITH STOCK AXLES & STOCK TRANSFER CASE & STOCK SUSPENSION**

**VEHICLES THAT WILL RECEIVE OVERSIZED TIRES SHOULD CHECK BALL JOINTS, TIE RODS ENDS AND IDLER ARM EVERY 2500-5000 MILES FOR WEAR AND REPLACE AS NEEDED**

**READ ALL INSTRUCTIONS THOROUGHLY FROM START TO FINISH BEFORE BEGINNING INSTALLATION! IF THESE INSTRUCTIONS ARE NOT PROPERLY FOLLOWED, SEVERE FRAME, DRIVELINE AND / OR SUSPENSION DAMAGE MAY RESULT.**

**NOTE- PRIOR TO THE INSTALLATION OF THIS SUSPENSION SYSTEM A FRONT END ALIGNMENT MUST BE PERFORMED AND RECORDED. DO NOT INSTALL THIS SYSTEM IF THE VEHICLE ALIGNMENT IS NOT WITHIN FACTORY SPECIFICATIONS. CHECK FOR FRAME AND SUSPENSION DAMAGE PRIOR TO INSTALLATION. THIS SUSPENSION SYSTEM DOES REQUIRE WELDING FOR INSTALLATION.**

**THE INSTALLATION OF THIS SUSPENSION SYSTEM SHOULD BE PERFORMED BY TWO PROFESSIONAL MECHANICS. CHECK ALL PARTS INCLUDED IN THIS KIT TO THE PARTS LIST ABOVE BEFORE BEGINNING INSTALLATION OF THE KIT. IF ANY PIECES ARE MISSING, CONTACT FABTECH AT 909-597-7800**

**TOOL LIST: (NOT INCLUDED)**

- FLOOR JACK & JACK STANDS
- ASSORTED METRIC AND S.A.E SOCKETS, & WRENCHES
- DIE GRINDER WITH CUTOFF WHEEL OR SAWZALL
- SANDING WHEEL
- TORQUE WRENCH
- MIG WELDER
- PITMAN ARM PULLER
- GREASE GUN

## FRONT SUSPENSION INSTRUCTIONS:

1. Disconnect the negative terminal on the battery. With the vehicle on level ground set the emergency brake and block the rear tires. Jack up the front end of the vehicle and support the frame rails with jack stands just behind the front bumper. **NEVER WORK UNDER AN UNSUPPORTED VEHICLE!** Remove the front tires. Support the front axle with a floor jack. Do not allow the axle to hang freely.
2. Working from both sides of the vehicle, remove and discard the front track bar and factory hardware.
3. Remove the sway bar end links and discard.
4. Remove the brake calipers and tie it out of way. **DO NOT ALLOW THE BRAKE CALIPERS TO HANG FROM BRAKE LINE.** SEE PHOTO BELOW.



5. Remove the front shocks and discard. Save the factory lower shock hardware, discard upper hardware.
6. Remove front coil springs and discard. Remove factory upper bump stop and discard.
7. Remove the front drive shaft and save drive shaft and hardware.
8. Remove the rear drive shaft and discard. Save hardware.
9. With a transmission jack support transmission and transfer case. Remove the factory transmission crossmember/skid plate. Save the crossmember/skid plate and the four nuts from transmission mount. Discard the six frame bolts. **NOTE: A NEW FIXED YOKE ( FTS94004) AND FIXED YOKE C.V DRIVE SHAFT (FTS94005) FOR THE REAR DRIVE LINE WILL NEED TO BE INSTALLED WITH THIS KIT.** (Not included in kit). Install the fixed yoke kit at this time. The new CV rear driveshaft will be later in this installation.
10. Working from the driver side of the vehicle, locate the factory lower link arm, remove and discard. Save the factory hardware from the axle mount and the discard hardware from frame mount.

11. Locate the factory lower link arm mount on the frame. Mark and cut the pocket from the frame with a die grinder and cutoff wheel. You will want to completely remove the factory bracket from the frame. SEE PHOTOS BELOW.



12. Locate the new Fabtech subframe FT50045. Line up the new subframe to the frame rail, aligning the three factory transmission crossmember holes up with the three holes in the subframe, attach the subframe to frame using the supplied 1/2" x 3 1/2" bolts, and USS washers. **Note: These subframe bolts just installed will only be used for positioning the subframe at this time, they will need to be removed and reinstalled at a later time to attach the factory crossmember.** With a drill, drill a 1/2" hole through the frame, through the three additional holes in the subframe, (two holes located towards the front of the subframe, (two holes located towards the front of the subframe and one in the new rear pocket) and attach with the supplied 1/2" x 1 1/2" button head bolts, washers, and nut tabs FT50058 (front driver) and FT50060. The nut tabs will be inserted into the frame from the factory holes on the outside of the frame located above the holes drilled. **BEFORE DRILLING THE FRAME CHECK FOR ELECTRICAL WIRES AND FUEL LINES.** Torque the bolts to 70 ft lbs. Remove the 3 bolts initially installed. SEE PHOTO ON NEXT PAGE.



13. Locate the new Fabtech front lower link arm FT50030, (29" long center to center) install one of the supplied grease fittings into each end of the link arm. Using a grease gun with chassis lube attach it to the grease fittings and lube the link ends. Install the link arm into the stock mount on the axle with factory hardware and to the new Fabtech subframe with the supplied 9/16" x 4" bolt, nut, and washers. Leave loose. **Note: When installing the Fabtech link arm, make sure the gussets on the link arms are facing down.**
14. Locate the factory upper link arm. Remove and discard. Save the hardware from axle mount and discard the hardware from the frame mount.
15. Locate the new Fabtech upper link arm FT50031, install a supplied grease fitting into the end with the barrel. Using a grease gun with chassis lube attach it to the grease fittings and lube the link ends. Install the link arm to the factory axle mount with factory hardware and to the new Fabtech subframe with the supplied 7/16" x 3" bolt, nut, and washer. Leave loose. **Note: When installing the Fabtech link arm, make sure the gussets on the link arms are facing down.**
16. Disconnect the factory brake line tab from the frame, save the hardware and the discard tab. Disconnect the factory brake line from the caliper, discard washers, and save banjo bolt. Disconnect the brake line from frame and discard the brake line. Locate the new Fabtech extended brake line FT50034 and new brake line bracket FT50055, slide the new brake line bracket onto the factory hard line and connect the bracket to the frame in the factory location using the factory hardware. Connect the new Fabtech brake line to the factory hard line on the frame, then connect to the brake caliper using two of the new supplied crush washers, one on each side of the banjo fitting. Using the supplied FTT79 brake line clip, attach the brake line to the brake line bracket. SEE PHOTO IN NEXT COLUMN.



17. Locate the supplied brake line retaining spring and adel clamp. Using a drill, drill a guide hole directly below the brake line bracket on the frame. Attach the spring to the frame using the supplied 5/16" self tapping screw. Attach the other end on the spring to the brake line using the supplied adel clamp and 1/4" bolt, nut, and washer. SEE PHOTO BELOW.



18. Locate the new Fabtech Urethane bump stop FT50027. Install into the factory location by pushing the bump stop into the factory cup. SEE PHOTO BELOW.



19. Locate the new Fabtech lower aluminum bump stop FT50052. Using a drill, drill a 5/16" hole through the center of the lower coil spring mount. Using the supplied 5/16" x 2" bolt, nut, and washer attach to the lower coil spring mount. SEE PHOTO ON NEXT PAGE.



20. Locate the new Fabtech upper sway bar end link bracket FT50013. Attach to the factory sway bar with the included 3/8" nyloc nut and washer. Locate the new Fabtech lower sway bar end link bracket FT50036 (**Note; there is a driver and passenger lower sway bar end link bracket: take care to locate the correct bracket. When installing bracket onto vehicle make sure the key way on the new bracket is locked into the factory mount and that the bracket is tilted towards the front of the Jeep and spot welded**). Attach to the factory axle mount with the supplied 1/2" x 1 1/2" bolt, nut, and washer, once attached weld the bracket to the axle mount. Locate the new Fabtech sway bar end link FT50070 (**Note: There is a driver and passenger sway bar end link, see drawing in right column**) and press one bushing and one sleeve from the supplied bushing kit into each end of the end link. With the supplied 1/2" x 2 3/4" bolt, nut, and washers connect to the upper sway bar mount. Locate the new Fabtech quick disconnect frame bracket FT50067. With the supplied Fabtech quick disconnect pin FT50025, connect to the quick disconnect bracket, as shown in the picture in the right column. Once connected swing the sway bar end link with bracket forward until the bracket comes in contact with the frame. Mark the spot on the frame with a center punch and drill a 9/32" guide hole. With the supplied 5/16" self tapping bolt, attach the quick disconnect bracket to the frame. **Do not connect the sway bar to the axle at this time.** SEE PHOTOS BELOW.



Note position of bracket, slight tilt forward

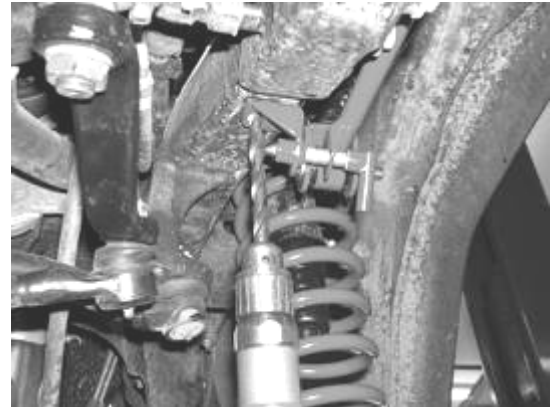

Note location of disconnect tab on the sway bar end link, upper inner side.

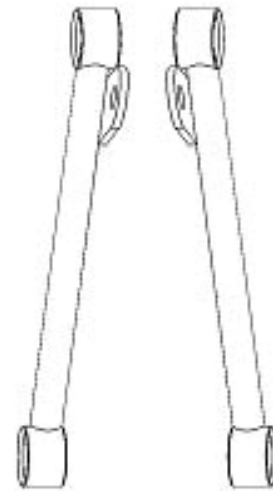

Drv. End Link

Pass. End Link

21. Repeat steps ten through twenty on passenger side of the vehicle.
22. Torque upper link arm bolts at the axle mounts to 55 ft lbs. Torque the front upper link arm at the subframe mount to 65 ft lbs. Torque the lower link arms at the subframe mounts to 130 ft lbs. Torque the lower link arm bolts to the axle mounts to 85 ft lbs.
23. Locate the factory transfer case shift linkage on the driver side of the transmission. Remove the two bolts securing the linkage to the body. (**On some models you may need to**

remove the linkage pivot arm from the vehicle and bend the tab connecting the linkage pivot arm to the floor shifter to clearance the new linkage drop bracket bolts. It is recommended to install the linkage drop first to check for clearance, if clearance is needed then proceed in bending the tab). Locate the new Fabtech linkage drop bracket FT50063. Using the supplied 1/4 x 1" bolts, nuts, and washers attach bracket to the factory linkage. Using the factory hardware attach the Fabtech bracket to the body. **NOTE: WHEN INSTALLATION OF LIFT KIT IS COMPLETE YOU MAY NEED TO ADJUST LINKAGE ROD ON THE TRANSFER CASE LINKAGE FOR PROPER SHIFTING. SEE PHOTOS BELOW.**



Linkage Pictured Bent Above



View from rear of vehicle forward

24. On manual transmission models you will need to remove the shifter arm from the center console of the truck and make a small bend in the shift arm as shown below. SEE PHOTO BELOW.



Shifter Unbent



Shifter Bent

25. Locate the factory transmission crossmember/skid plate, reinstall onto the vehicle using the supplied 1/2" x 3 1/2" bolts and USS washers. **Note: These are the same bolts used to position the subframe on the vehicle earlier.** Reattach the 4 factory transmission mount nuts in the center of the pan, torque to 40 FT LBS. Torque the frame bolts to 85 FT LBS.
26. Locate the factory front drive shaft. Reconnect to the transfer case using factory hardware. Using a die grinder with a cut off wheel you will need to clearance the factory crossmember/skid plate to allow room for the driveshaft at full suspension droop. Once the crossmember/skid plate has been cleared reconnect drive shaft to the front axle. Use a small amount of the supplied thread locking compound on all the drive shaft bolts. Torque drive shaft bolts to 14 ft lbs. SEE PHOTO BELOW



27. Locate the factory pitman arm, disconnect the inner tie rod end from the pitman arm, remove the pitman arm with a pitman arm puller and discard. Locate the new Fabtech drop pitman arm FT50015 and install it onto the steering box using the factory nut and washer. Torque nut to 185 ft lbs. Reconnect the inner tie rod end using factory hardware. Torque to 45 ft lbs.



28. Locate the factory steering stabilizer bolt connecting it to the axle. Remove bolt and discard. If installing a Fabtech Steering Stabilizer FTS8006 do so at this time. Using the supplied 12mm button head bolt, nut, and washer reconnect the stabilizer. SEE PHOTO BELOW.



29. Locate the new Fabtech front lift coil springs, and install into the vehicle.
30. Locate the new Fabtech front shocks FTS7174 (not included in kit) and install. You will reuse the factory lower hardware and the supplied upper hardware. Torque all front shock bolts to 20ft lbs.
31. Locate the new Extended Trac Bar FT50029. Locate one FT30 Rod End and one FTS50 Jam Nut. Thread the jam nut all the way onto the rod end. From bushing kit FT50051 use two bushing halves and one sleeve press them into the rod end. Thread the rod end into the bottom end of the Fabtech Trac Bar so  $\frac{3}{4}$ " of thread are still showing out side the trac bar. Locate one FTS98000 Heim Joint and thread one FTS50 Jam Nut all the way onto the end of the Heim Joint. Install the Heim joint into the end of the Trac Bar. The Heim joint should be threaded into the Trac Bar so  $\frac{3}{4}$ " of thread are out of the trac bar. Install two FT43 misalignment spacers into the heim joint. (The rod end will be installed into the end with the gusset on the inner side, and the heim joint will go on the end the gusset on the outer side, both gussets will be facing up).

32. Locate the factory trac bar axle mount hole. Using a drill with a  $\frac{1}{2}$ " drill bit, drill the factory mounting hole for the trac bar on the axle out. Using the supplied  $\frac{1}{2}$ " X  $3\frac{1}{2}$ " bolt, FT50097 nut tab, and washer attach the rod end of the trac bar to the factory axle mount, leave loose. Using a drill with a  $\frac{3}{4}$ " drill bit, drill the factory frame mount hole out. Attach the end with the heim joint to the factory frame mount using the supplied  $\frac{1}{2}$ " X 4" bolt, c-lock nut, SAE washer, FT97150-6-106 thick flat washer, and FT81 Frame insert. The larger  $\frac{3}{8}$ " thick flat washer will be located on the topside of the frame mount along with one flat washer, and the frame insert will be installed into the frame from the bottom side of the frame. When installing the trac bar make sure the gussets on the trac bar are facing up. **SEE THE DRAWING BELOW FOR THE COMPLETE**

**ORDER OF INSTALLATION. When installing the upper heim joint to the frame make sure the heim joint is parallel to the frame as shown in the drawing below.** Torque trac bar bolts to 70 ft lbs. Torque Jam Nuts to 70 ft lbs. Adjustment to the heim joint and rod end can be made once vehicle is on the ground to center the axle. The jam nuts just installed should be retorqued after the first 100 miles. SEE PHOTO BELOW



Lower Trac Bar Mount

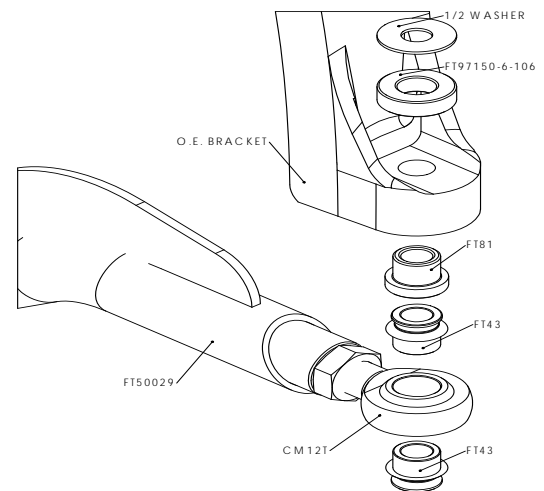

Front Upper Trac Bar Mount

33. Install the wheels and tires, and torque to wheel manufactures specs. Set the Jeep back on ground.
34. Locate the factory steering stops and remove and discard. Locate the supplied  $\frac{3}{8}$ " fine thread bolt and nut. Thread one nut onto one bolt  $\frac{3}{4}$ " from the head of the bolt. Install bolt with nut into the factory steering knuckle. While steering the vehicle lock to lock adjust the steering stop to allow for clearance for braking system. Tighten nut against the factory steering knuckle to 50 ft lbs.

35. Attach sway bar end links to axle mounts using the supplied FT42 Pin and FT90036 Lynch Pin. Attach the FT45 key ring to the FT42 Pin. SEE PHOTO BELOW.

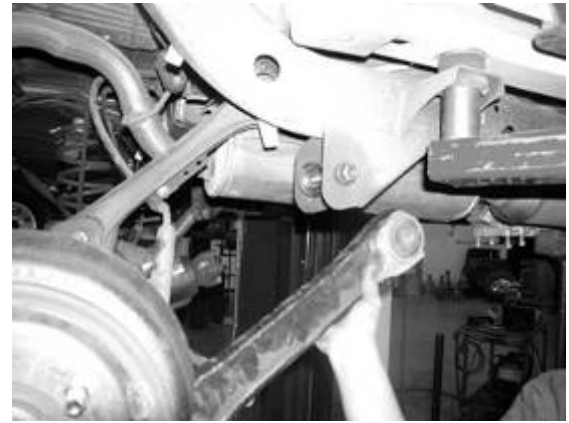

43. Locate the factory lower link arm frame pocket, using a die grinder with a cutoff wheel cut the link arm pocket from the frame. Clear the bracket completely from the frame. SEE PHOTO BELOW.



## **REAR SUSPENSION INSTRUCTIONS:**

36. Jack up the rear end of the vehicle and support the frame rails with jack stands just in front of the rear bumper. Supporting the rear differential remove and discard the rear shocks. Use care not to over extend the brake hoses.
37. Locate and remove the track bar, discard track bar and hardware.
38. Locate and remove the factory sway bar end links, discard the end links and save the hardware.
39. Locate the brake line tabs and the emergency cable tabs on the factory upper link arms, disconnect and save the hardware.
40. Locate the emergency brake cable bracket mounted to the body above the differential. Remove and allow to hang freely, save the factory hardware.
41. Locate and remove the factory coil springs and bump stops. Discard coil springs and the bump stops.
42. Working from the driver side of the vehicle, remove and discard the lower link arm. Discard the factory hardware. SEE PHOTO NEXT COLUMN.

44. Locate the shock mount on the axle. Using a die grinder with a cut off wheel, cut shock mount completely from the axle. Locate the new axle shock mount FT50056, **Note there is a driver and passenger side lower shock mount, FT50056 is the driver side and FT50057 is the passenger side.** Using the stock link arm pivot bolt from the axle mount, connect the new shock mount to the factory lower link arm mount on the axle (do not tighten this bolt up, it is only being used for positioning of the new shock mount at this time). Swing the shock mount up to meet the axle completely. Using a Mig welder, weld the shock mount to the axle. Remove the bolt from link arm mount. SEE PHOTO BELOW.



45. Locate the factory upper link arm, remove and discard the link arm and save the hardware.
46. Locate the Fabtech upper link arm FT50033 (driver side) and the lower FT50032 (27.5" long center to center), install one of the supplied grease fittings into each end of the link arms. Using a grease gun with chassis lube attach it to the grease fittings and lube the link ends. Using the supplied 9/16" x 7" bolt, nut, and washers attach the new link arms to the Fabtech subframe. **Note: When mounting the link arms to the sub frame, make sure the gussets on the lower link arm face down and the gussets on the upper link arm are facing up, the upper link arm is mounted in the inboard pocket.** Using the supplied 7/16" x 3" bolt, nut, and washer attach the upper link arm to the axle, and using the supplied 9/16" x 5" bolt, nut, and washer attach the lower link arm to the axle. **When installing the upper link arms make sure the e-brake cables are located below the upper link arm.** Leave loose. SEE PHOTO BELOW.



47. Locate the upper bump stop cup, remove and discard the bolt. Locate the bump stop drop spacer FT50062 using the supplied 1/2"-13 x 5" long bolt, washer and nut, install the spacer between the bump stop cup and upper coil seat. A 1/2" drill may be necessary. Locate the Fabtech upper bump stop FT50027, install into the stock location. SEE PHOTO BELOW.



48. Locate the new lower bump stop FT50052. Using a drill, drill a 5/16" hole through the center of the lower coil spring mount. Using the supplied 5/16" x 2" bolt, nut, and washer

attach to the lower coil mount. SEE PHOTO IN NEXT COLUMN.



49. Locate the previously removed e-brake cable from the upper link arms. Reattach to the Fabtech link arms using factory hardware on the passenger side and the supplied 5/16" bolt, nut, and washer on the driver side. SEE PHOTO BELOW.



Driver Side Shown

50. Repeat steps forty one through forty eight on the passenger side of the vehicle.
51. Locate the Fabtech emergency brake cable drop bracket FT50038. Using the factory hardware attach to the body. Using the supplied 5/16" x 1" bolt, nut, and washers attach the factory bracket to the new Fabtech drop bracket. SEE PHOTO BELOW.



52. Locate the factory brake hose from the frame to the rear axle. Remove and discard hose, save the factory hardware

from the frame mount. Locate the Fabtech rear brake hose FT50035 and brake line bracket FT50055. Slide the new brake hose through the new bracket and attach the brake hose to the hard line on the frame first then attach it to the hard line on the axle. Attach the brake line tab to the frame using the factory hardware. Using the supplied brake hose clip FT90037 attach the brake hose to the bracket. SEE PHOTO BELOW.



53. Locate the Fabtech rear lift coil springs, and install onto the vehicle.
54. Locate the Fabtech rear shocks FTS7175 (not included in kit) and install onto the vehicle with the shock shaft down and the body up reusing the factory hardware on the upper mount and the supplied 1/2" bolt, nut, and washer on the lower mount. Torque to 17 ft. lbs.
55. Locate the new sway bar end links FT50037. Install one 5/8" hourglass bushing, and one sleeve into each end of the end links. Install the end links on to the vehicle using the factory hardware. Torque to 45 ft lbs.
56. Locate the Fabtech rear axle Trac bar bracket FT50053. Line the lower hole in the Fabtech bracket up with the factory hole, using a drill, drill a 1/2" hole through the side of the factory mount. Using the supplied 1/2" x 1 1/4" bolt, nut, and washer start bolt. Locate sleeve FT46, slide the sleeve into the factory mounting pocket in the axle mount. Using the supplied 1/2" bolt, nut, and washer attach bracket. Torque both bolts to 75 ft lbs. SEE PHOTO BELOW.



57. Locate the Fabtech upper frame Trac bar bracket FT50054. Using the supplied 1/2" x 1 1/4" bolt, and washer and

1/2" bolt, nut, and washer attach the bracket to the frame. Torque both bolts to 75 ft. lbs. SEE PHOTO IN NEXT COLUMN.



58. Locate the Extended Trac Bar FT50039, one FT30 Rod End and one FTS50 Jam Nut. Thread the jam nut all the way onto the rod end. From bushing kit FT50051, use two bushing halves and one sleeve and press them into the rod end. Thread the rod end into the top end of the trac bar (the bottom end of the trac bar is the end with out the bend). Locate one FTS98000 Heim Joint and thread one FTS50 Jam Nut on to the heim joint and install the heim joint into the bottom end of the Trac Bar. Both the Heim Joint and Rod End need to be threaded into the Trac Bar so 3/4" of thread are showing above the jam nut (this is only a starting point, further adjustment may be required once the vehicle is on the ground).
59. Using the supplied 1/2" X 3 1/2" bolt, nut, and washer attach the trac bar to the upper trac bar bracket, leave loose. Using the supplied 1/2" X 3 1/2" bolt, nut, and washer attach the trac bar to the axle bracket. Torque both trac bar bolts to 100 ft lbs. Torque Jam Nuts to 70 ft lbs. **(When the vehicle is complete and back on the ground you will be able to adjust the heim joint and the rod end to center the axle).** SEE PHOTO BELOW. ( some models may require tailpipe modifications for proper trac bar clearance)



60. Working from the driver side of the vehicle, locate the three outer tabs on the Fabtech Subframe. With a sanding wheel, clear the powder coat from the tabs and paint from the frame. Using a Mig Welder, weld the tabs to the frame. Once the weld has cooled spray paint all raw metal areas of the frame to prevent rust. Repeat on the passenger side of the truck. SEE PHOTO ON NEXT PAGE.



61. Install the new CV style rear drive shaft FTS94005 (not included with this kit).
62. Bleed the front and rear brake lines per Jeep's factory service instructions.
63. Install rear tires and wheels and torque lug nuts to wheel manufacturer's specifications. Turn front tires left to right and check for appropriate tire clearance.

64. With the vehicle on the ground position the tires straight ahead and adjust the draglink to center the steering wheel. Once the steering wheel has been centered tighten the draglink adjuster bolts to 30 ft. lbs.
65. With front wheels positioned straight ahead measure the front and rear axle to make they are centered on the truck. Adjust the heim joints and rod ends on the trac bars to center axles as needed.
66. Recheck all nuts and bolts for proper torque tightness before driving. Install driver warning sticker to driver door post or jam. Drive the vehicle for 20 miles and have it aligned to factory specifications. Check Transfer Case fluid and fill as required.
67. Check front-end alignment and set to factory specifications. Re-adjust headlights.

**RETORQUE ALL NUTS, BOLTS AND LUGS AFTER 50 MILES AND PERIODICALLY THEREAFTER.**

For technical assistance call: 909-597-7800

## Product Warranty and Warnings-

Fabtech provides a Limited Lifetime Warranty to the original retail purchaser who owns the vehicle, on which the product was originally installed, for defects in workmanship and materials.

The Limited Lifetime Warranty excludes the following Fabtech items; bushings, bump stops, ball joints, tie rod ends, limiting straps, cross shafts, heim joints. These parts are subject to wear and are not considered defective when worn. They are warranted for 60 days from the date of purchase for defects in workmanship.

Take apart shocks are considered a serviceable shock with a one year warranty on leakage only. Service seal kits are available separately for future maintenance. All other shocks are covered under our Limited Lifetime Warranty.

Fabtech does not warrant any product for finish, alterations, modifications and/or installation contrary to Fabtech's instructions. Alterations to the finish of the parts including but not limited to painting, powdercoating, plating and/or welding will void all warranties. Some finish damage may occur to parts during shipping which is considered normal and is not covered under warranty.

Fabtech products are not designed nor intended to be installed on vehicles used in race applications or for racing purposes or for similar activities. (A "RACE" is defined as any contest between two or more vehicles, or any contest of one or more vehicle against the clock, whether or not such contest is for a prize). This warranty does not include coverage for police or taxi vehicles, race vehicles, or vehicles used for government or commercial purposes. Also excluded from this warranty are sales outside of the United States of America.

Installation of most suspension products will raise the center of gravity of the vehicle and will cause the vehicle to handle differently than stock. It may increase the vehicle's susceptibility to a rollover, on road and off road, at all speeds. Extreme care should be taken to operate the vehicle safely at all times to prevent rollover or loss of control resulting in serious injury or death. Fabtech front end Desert Guards may impair the deployment or operation of vehicles equipped with supplemental restraining systems/air bag systems and should not be installed if the vehicle is equipped as so.

Fabtech makes every effort to ensure suspension product compatibility with all vehicles listed in the catalog, but due to unknown auto manufacturer's production changes and/or inconsistencies by the auto manufacturer, Fabtech cannot be responsible for 100% compatibility, including the fitment of tire and wheel sizes listed. The Tire and Wheel sizes listed in Fabtech's catalog are only a guideline for street driving with noted fender trimming. Fabtech is not responsible for damages to the vehicle's body or tires.

Fabtech's obligation under this warranty is limited to the repair or replacement, at Fabtech option, of the defective product only. All costs of removal, installation or re-installation, freight charges, incidental or consequential damages are expressly excluded from this warranty. Fabtech is not responsible for damages and/or warranty of other vehicle parts related or non related to the installed Fabtech product. This warranty is expressly in lieu of all other warranties expressed or implied. This warranty shall not apply to any product that has been subject to accident, negligence, alteration, abuse or misuse as determined by Fabtech.

Fabtech suspension components must be installed as a complete system including shocks as shown in our current catalog. All warranties will become void if Fabtech parts are combined and/or substituted with other aftermarket suspension products. Combination and/or substitution of other aftermarket suspension parts may cause premature wear and/or product failure resulting in an accident causing injury or death. Fabtech does not warrant products not manufactured by Fabtech.

Installation of Fabtech product may void the vehicles factory warranty; it is the consumer's responsibility to check with their local vehicle's dealer for warranty disposition before the installation of the product.

It is the responsibility of the distributor and/or the retailer to review all warranties and warnings of Fabtech products with the consumer prior to purchase.

Fabtech reserves the right to supercede, discontinue, change the design, finish, part number and, or application of parts when deemed necessary without written notice. Fabtech is not responsible for misprints or typographical errors within the catalog or price sheet.