

INSTALLATION INSTRUCTIONS

FTS835242D		FORD SUPERDUTY 4.0 COILOVER
1	FT30717	LOWER COILOVER MOUNT (DRIVER)
1	FT30726	UPPER COILOVER MOUNT (DRIVER)
1	FT86077	HARDWARE KIT 77
1	FT86078	HARDWARE KIT
1	FT86094	HARDWARE SUBASSEMBLY

FTS835242P		FORD SUPERDUTY 4.0 COILOVER
1	FT30718	LOWER COILOVER MOUNT (PASSENGER)
1	FT30727	UPPER COILOVER MOUNT (PASSENGER)
1	FT86077	HARDWARE KIT 77
1	FT86078	HARDWARE KIT
1	FT30728	DRILL GUIDE

FT86077		HARDWARE KIT 77
1	FT83245	UPPER MOUNT BUSHING (LARGE)
1	FT83246	UPPER SHOCK BUSHING (SMALL)
2	FT83474	SPACER (UPPER)
2	FT83475	5/8" SPACER (LOWER)
2	FT89016	HOSE CLAMP

FT86078 - HARDWARE KIT		LOCATION
2	M14-2.0 X 30MM HEX BOLT	LOWER MOUNT
2	M14 FLAT WASHER	
3	7/16" USS FLAT WASHER	UPPER MOUNT
3	7/16-14 C-LOCK NUT	
2	1/2" SAE WASHER	
1	1/2-13 C-LOCK NUT	
1	1/2-13 X 2-1/2" HEX BOLT	
2	5/8" SAE WASHER	
1	5/8-11 C-LOCK NUT	
1	5/8-11 X 3-1/2" HEX BOLT	
2	1/4-20 X 1" HEX BOLT	BRAKE LINE
4	1/4" SAE WASHER	
2	1/4-20 NYLOCK NUT	
2	3/8-16 X 1-1/4" HEX BOLT	ABS BRACKET
4	3/8" WASHER	
2	3/8-16 NYLOCK NUT	
1	5/16-18 X 1" HEX BOLT	ABS TAB
2	5/16" WASHER	
1	5/16-18 NYLOCK NUT	

FT86094		HARDWARE KIT 94
1	FT30664	BRAKE LINE BRACKET
1	FT30688	ABS TAB
1	FT30728	DRILL GUIDE
2	FT30929	ABS SPACER
2	31181501081	5/16-18 X 1-1/2 HEX BOLT
4	31000005052	5/16" SAE WASHER
2	31180004152	5/16-18 C-LOCK NUT

2017-2022 FORD F-250/F-350 SUPERDUTY 4.0 COILOVER CONVERSION KIT FOR 4" KITS

FT835232i

Fabtech Motorsports | 4331 Eucalyptus Ave. Chino, CA 91710

Tech Line: 909-597-7800 | Fax: 909-597-7185 | Web: www.fabtechmotorsports.com

- TOOL LIST -

Required Tools (Not Included)

-Basic Hand Tools
-Floor Jack
-Jack Stands

-Torque Wrench
-Die Grinder w/ Cutoff Wheel or Sawzall
-Assorted Metric and S.A.E sockets, and Allen wrenches

- PRE-INSTALLATION NOTES -

For technical assistance call: **909-597-7800** or e-mail: **info@fabtechmotorsports.com**

READ THIS BEFORE YOU BEGIN INSTALLATION -

Check all parts to the parts list above before beginning installation. If any parts are missing contact Fabtech at 909-597-7800 and a replacement part will be sent to you immediately.

Read all instructions thoroughly from start to finish before beginning the installation. If these instructions are not properly followed severe frame, driveline and / or suspension damage may occur.

Check your local city and state laws prior to the installation of this system for legality. Do not install if not legal in your area.

Prior to the installation of this suspension system perform a front end alignment and record. Do not install this system if the vehicle alignment is not within factory specifications. Check for frame and suspension damage prior to installation.

The installation of this suspension system should be performed by two professional mechanics.

This suspension must be installed with Fabtech shock absorbers.

Use the provided thread locking compound on all hardware.

WARNING- Installation of this system will alter the center of gravity of the vehicle and may increase roll over as compared to stock.

Vehicles that receive oversized tires should check ball joints, uniballs, tie rods ends, pitman arm and idler arm every 2500-5000 miles for wear and replace as needed.

Verify differential fluid is at manufactures recommended level prior to kit installation. Installation of the kit will reposition the differential and the fill plug hole may be in a different position. (For example, if the manufacture recommends 3 quarts of fluid, make sure the diff has 3 quarts of fluid). Check your specific manual for correct amount of fluid.

FOOTNOTES -

- WILL NOT WORK WITH LEVELING OR BASIC SYSTEM***
- WILL NOT FIT GAS MOTOR VEHICLES***

NOTE: TO ORDER WEARABLE REPLACEMENT COMPONENTS DO NOT USE PART NUMBERS SHOWN ON THIS INSTRUCTION SHEET. GO TO FABTECH WEBSITE AND LOOK UP WEARABLE REPLACEMENT PARTS TO FIND THE PROPER PART NUMBER TO ORDER.

- INSTRUCTIONS -

1. Disconnect the negative terminal on the battery. Jack up the front end of the truck and support the frame rails with jack stands. **NEVER WORK UNDER AN UNSUPPORTED VEHICLE!** Remove the front tires.
2. Disconnect the sway bar from the end links and the factory brake line bracket from the lower coil spring perch. **SEE FIGURE 1.** Repeat on Passenger side.

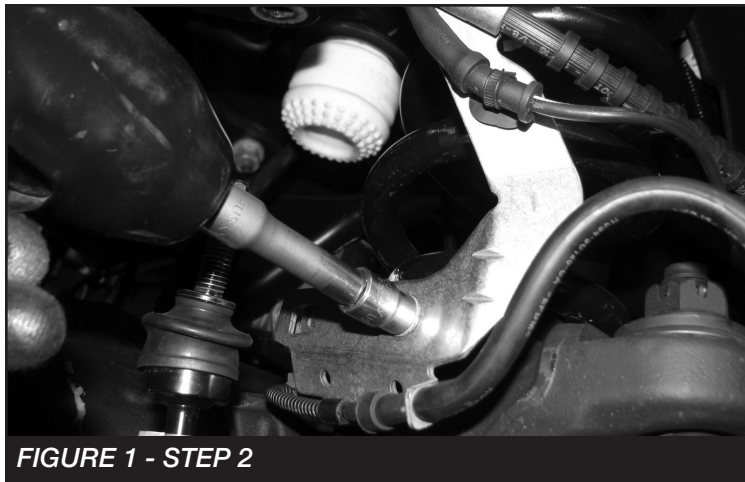

FIGURE 1 - STEP 2

3. Disconnect the track bar from the track bar bracket. Save hardware.
4. Remove and discard the front shocks, coil springs and upper rubber isolators from both sides. Save lower shock hardware.
5. Remove the lower coil spring perch from the axle and discard. Repeat on passenger side.
6. **(DRIVER SIDE ONLY)** Remove the driver side inner fender liner. Locate the ABS module mounted to the factory spring perch. Remove and save the bolt attaching the bracket to the front of the spring perch. Using a 13mm wrench remove the (2) nuts that attach the L bracket together. Then using the same 13mm wrench remove the nuts attaching the same bracket to the back side of the factory spring perch. Discard the factory bracket and save the hardware. **2020 Models** - Remove the factory bolt assembly attaching the ABS module to the coil bucket. **SEE FIGURE 2**



FIGURE 2 - STEP 6

7. **2017-2019 Models** - Locate and install FT30664 (ABS Bracket) in the same location as the factory bracket previously removed using the factory nuts on the spring perch and the supplied 3/8" X 1-1/4" hardware. Torque to 52 ft-lbs. **SEE FIGURE 3**



FIGURE 3 - STEP 7

8. **2020-2022 Models** - Install two FT30929 (ABS Module spacer) between the ABS bracket and the upper shock mount bracket using the supplied 5/16" x 1-1/2" bolts, washers and nuts. **SEE FIGURE 4**

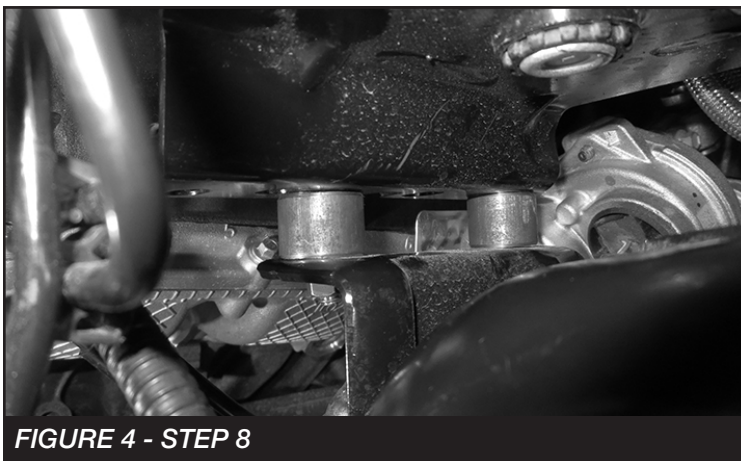

FIGURE 4 - STEP 8

9. Install FT30688 (ABS Tab) using the factory and 5/16" hardware. Torque to 29 ft-lbs. **SEE FIGURE 5**



FIGURE 5 - STEP 9

- Reinstall the fender liner -

10. Locate FT30728 (Drill guide). Place the guide up in the upper coil spring mount with the notch facing towards you. Measure 4-3/4" from the edge of the mount. Place the notch at the 4-3/4" mark. Next, mark the 3 holes and remove the guide. **SEE FIGURES 6**

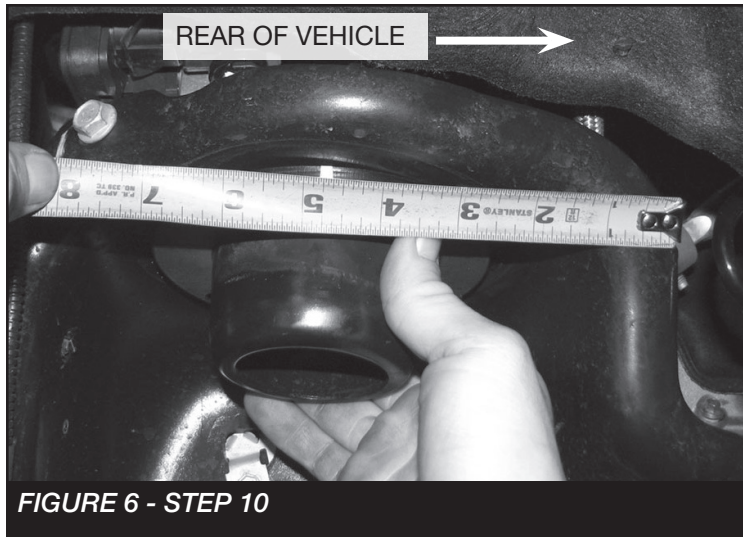

11. Locate the upper coil spring perch. The locator tube will need to be cut off using a reciprocating saw or cut off wheel. Sand to a smooth finish. **SEE FIGURES 7-8**

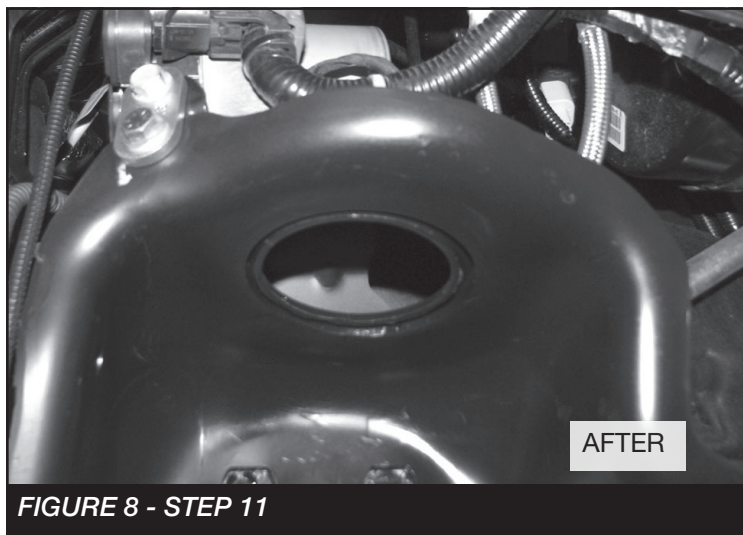
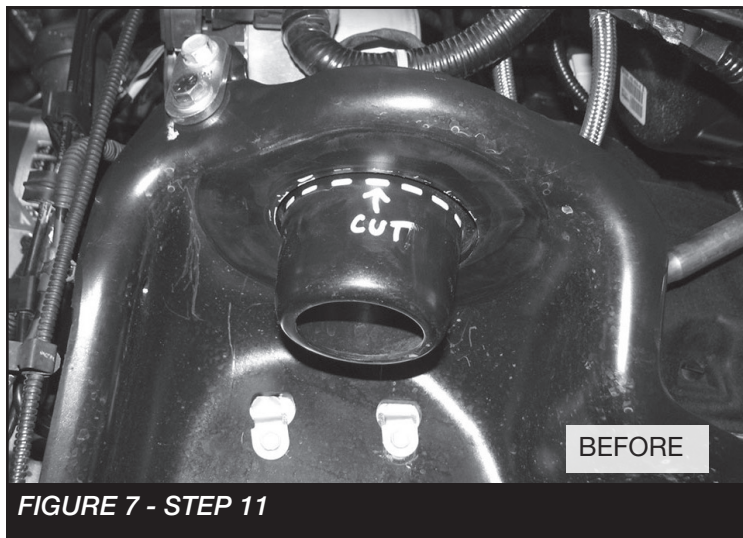

12. Using a drill and a 1/2" drill bit. Drill the 3 holes that were previously marked in step 9. Paint all bare areas. **SEE FIGURE 9**

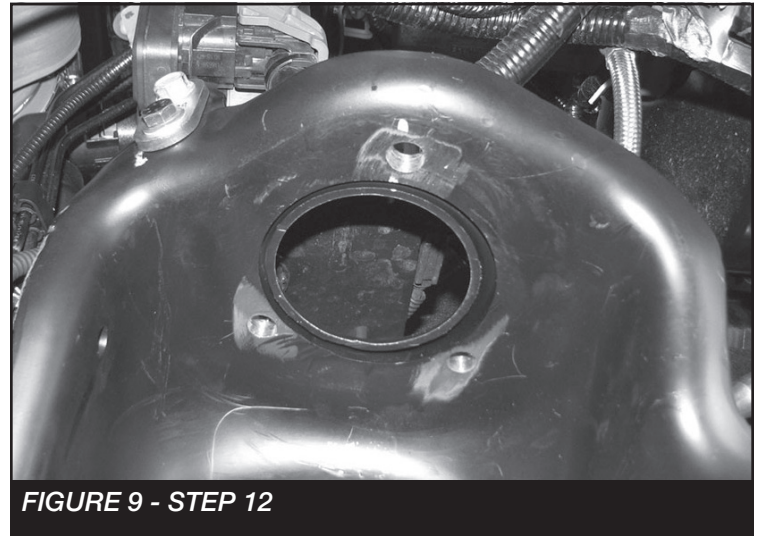

13. REPEAT STEPS 10-12 ON PASSENGER SIDE

14. Locate the Driver side Coilover, FT30726 (Driver upper coilover mount), FT83245 (large bushing, FT83246 (small bushing), two of the FT83474 (1/2" ID misalignment) 1/2" X 2-1/2" bolt and hardware. Using **FIGURE 10** install the upper mount on the coilover with the misalignments and bushings. **NOTE: The resi hose will orientate towards the rear of the vehicle and the 1/2" bolt will needs to be installed from the back side.** Torque to 127 ft-lbs. Once complete set aside.

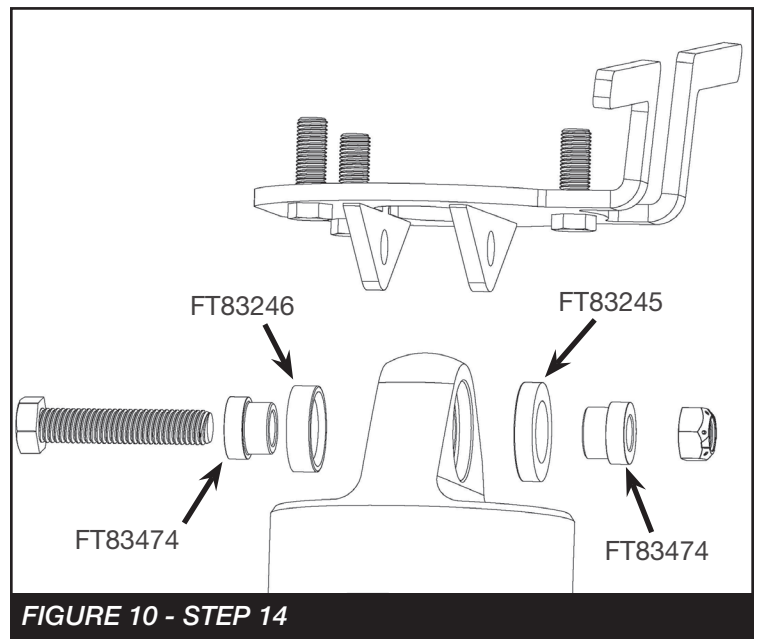

15. REPEAT STEP 14 FOR THE PASSENGER SIDE. Use the Passenger side Coilover, FT30727 (pass upper mount) bushings, misalignments and 1/2" hardware. SEE FIGURE 11 FOR COMPLETED ASSEMBLY.

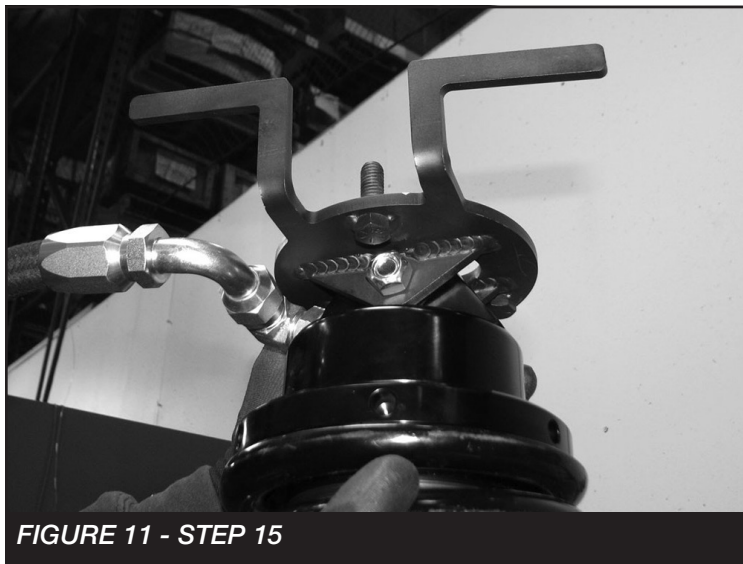

FIGURE 11 - STEP 15

16. Install FT30717 (Driver lower coilover mount) onto the driver side of the axle using the factory shock hardware at the factory shock location and M14 X 30mm bolt and washer at the lower spring perch location. Torque factory hardware to 100 ft-lbs and M14 to 160 ft-lbs. SEE FIGURE 12.

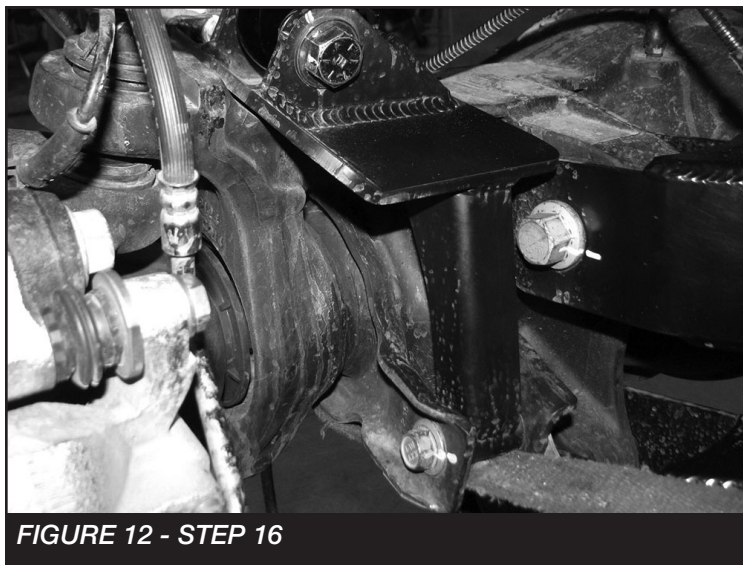

FIGURE 12 - STEP 16

17. REPEAT STEP 16 ON THE PASSENGER SIDE USING FT30718 (PASSENGER LOWER COILOVER MOUNT).

18. Install the driver side coilover mount using the supplied 7/16" nuts and washers for the upper mount and the 5/8" hardware with two FT83475 (Misalignments) at the lower mount. Torque 7/16" to 83 ft-lbs and 5/8" 254 ft-lbs. SEE FIGURE 13

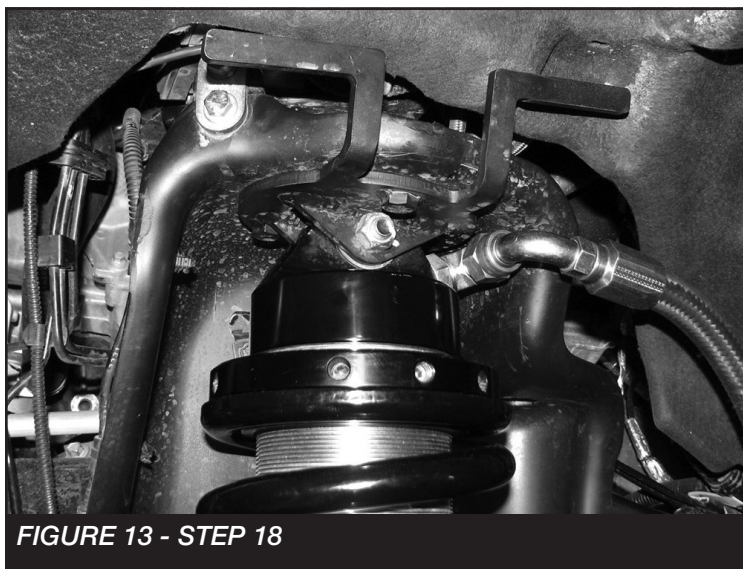

FIGURE 13 - STEP 18

19. Install the resi can to the resi mount using the supplied clamps. SEE FIGURE 14

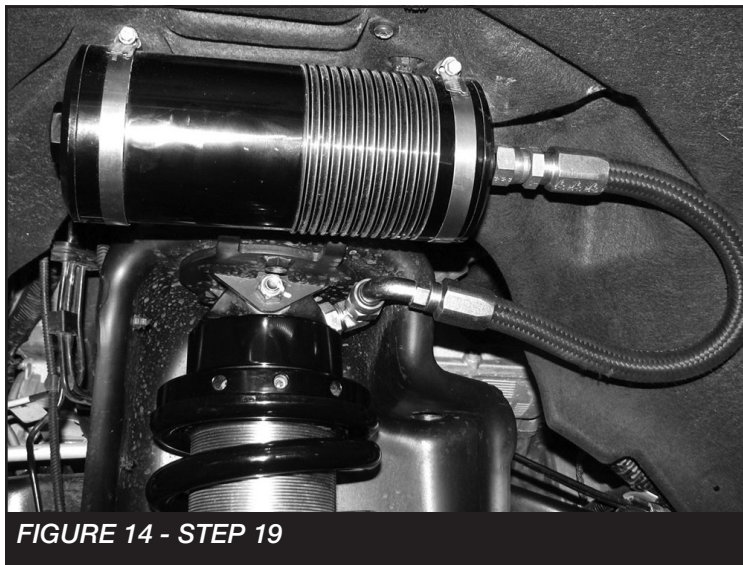

FIGURE 14 - STEP 19

20. REPEAT STEPS 18 & 19 ON THE PASSENGER SIDE

21. Install the factory brake line bracket to the new lower coilover mount using the supplied 1/4" hardware. Torque to 14 ft-lbs.
22. Reconnect the sway bar end links to the sway bar and track bar. Torque the track bar bracket bolt to 160 ft-lbs.

23. Install tires and wheels and torque lug nuts to wheel manufacturer's specifications. Turn front tires left to right and check for appropriate tire clearance. **Note - Some oversized tires may require trimming of the front bumper & valance.**
24. Check front end alignment and set to factory specifications. Readjust headlights.
25. Recheck all bolts for proper torque.
26. Recheck brake hoses, ABS wires and suspension parts for proper tire clearance while turning tires fully left to right.
27. Check the fluid in the front and rear differential and fill if needed with factory specification differential oil. **Note - some differentials may expel fluid after filling and driving. This can be normal in resetting the fluid level with the new position of the differential/s.**
28. Install Driver Warning Decal. Complete product registration card and mail to Fabtech in order to receive future safety and technical bulletins on this suspension.

Vehicles that will receive oversized tires should check ball joints, uniballs and all steering components every 2500-5000 miles for wear and replace as required.

**RE-TORQUE ALL NUTS, BOLTS AND LUGS
AFTER 50 MILES AND PERIODICALLY
THEREAFTER.**

For technical assistance call: **909-597-7800**

- Product Warranty and Warnings -

Fabtech provides a Limited Lifetime Warranty to the original retail purchaser who owns the vehicle, on which the product was originally installed, for defects in workmanship and materials.

The Limited Lifetime Warranty excludes the following Fabtech items; bushings, bump stops, ball joints, tie rod ends, limiting straps, cross shafts, heim joints and driveshafts. These parts are subject to wear and are not considered defective when worn. They are warranted for 60 days from the date of purchase for defects in workmanship.

Dirt Logic and Performance Coilover take apart shocks are considered a serviceable shock with a one year warranty on leakage only. Service seal kits are available separately for future maintenance. All other shocks are covered under our Limited Lifetime Warranty.

Fabtech does not warrant any product for finish, alterations, modifications and/or installation contrary to Fabtech's instructions. Alterations to the finish of the parts including but not limited to painting, powder coating, plating and/or welding will void all warranties. Some finish damage may occur to parts during shipping, which is considered normal and is not covered under warranty.

Fabtech products are not designed nor intended to be installed on vehicles used in race applications or for racing purposes or for similar activities. (A "RACE" is defined as any contest between two or more vehicles, or any contest of one or more vehicle against the clock, whether or not such contest is for a prize). This warranty does not include coverage for police or taxi vehicles, race vehicles, or vehicles used for government or commercial purposes. Also excluded from this warranty are sales outside of the United States of America.

Installation of most suspension products will raise the center of gravity of the vehicle and will cause the vehicle to handle differently than stock. It may increase the vehicle's susceptibility to a rollover, on road and off road, at all speeds. Extreme care should be taken to operate the vehicle safely at all times to prevent rollover or loss of control resulting in serious injury or death. Fabtech front end Desert Guards may impair the deployment or operation of vehicles equipped with supplemental restraining systems/air bag systems and should not be installed if the vehicle is equipped as so.

Fabtech makes every effort to ensure suspension product compatibility with all vehicles listed on the website, but due to unknown auto manufacturer's production changes and/or inconsistencies by the auto manufacturer, Fabtech cannot be responsible for 100% compatibility, including the fitment of tire and wheel sizes listed. The Tire and Wheel sizes listed in Fabtech's website are only a guideline for street driving with noted fender trimming. Fabtech is not responsible for damages to the vehicle's body or tires. Fabtech is not responsible for premature wear of factory components due to the installation of oversized tires and wheels.

Fabtech's obligation under this warranty is limited to the repair or replacement, at Fabtech option, of the defective product only. All costs of removal, installation or re-installation, freight charges, incidental or consequential damages are expressly excluded from this warranty. Fabtech is not responsible for damages and/or warranty of other vehicle parts related or non related to the installed Fabtech product. This warranty is expressly in lieu of all other warranties expressed or implied. This warranty shall not apply to any product that has been subject to accident, negligence, alteration, abuse or misuse as determined by Fabtech.

Fabtech suspension components must be installed as a complete system including shocks as shown on our website. All warranties will become void if Fabtech parts are combined and/or substituted with other aftermarket suspension products. Combination and/or substitution of other aftermarket suspension parts may cause premature wear and/or product failure resulting in an accident causing injury or death. Fabtech does not warrant products not manufactured by Fabtech.

Depending on the condition of the factory suspension components retained after the installation of a Fabtech suspension not all vehicles may have the same ride stance front to rear as described in the website. The blue color of suspension components shown in all Fabtech photographs are for display purposes only. Majority of all Fabtech components will be black specifically where noted with part numbers ending in BK.

Installation of Fabtech product may void the vehicles factory warranty; it is the consumer's responsibility to check with their local vehicle's dealer for warranty disposition before the installation of the product. Some state laws may prohibit modification of suspension to a vehicle in whole or in part. It is the responsibility of the installer and consumer to consult local laws prior to the installation of any Fabtech suspension product to comply with such written laws.

It is the responsibility of the distributor and/or the retailer to review all warranties and warnings of Fabtech products with the consumer prior to purchase.

Fabtech reserves the right to super cede, discontinue, change the design, finish, part number and/or application of parts when deemed necessary without written notice. Fabtech is not responsible for misprints or typographical errors within the website or price sheet. For the most recent Product Warranty and Warnings visit our website www.fabtechmotorsports.com